

WalzCraft® — “Your Single Source Provider” —

P.O. Box 1748, La Crosse, WI 54602-1748
2600 Hemstock St, La Crosse, WI 54603-2349
1-800-237-1326 (Fax) 1-608-781-3667
www.WalzCraft.com



Dear Valued Customer:

“Thank You” for taking the time to review our **2022, 18.1 Product Specifications Catalog** along with the **18.1 Wholesale Pricing Catalog**. We are confident that you will find these to be essential resources for your growing business over the coming months.

WalzCraft continues to build upon its industry-leading reputation by aspiring to be one of our nation’s leading custom kitchen cabinet door and cabinet component manufacturers. We strive to provide “all” of our customers the very highest level of quality on a daily basis, and to deliver your product as promptly as possible at the most affordable price. As a reliable **“Single Source Cabinet Door & Component Supplier”** we believe that you are now holding the key to a solid partnership, in your very own hands.

Our phones are answered by “real live people” who genuinely care about their customers. Please feel free to call us at 1-800-237-1326, Monday through Friday between 6:00 AM & 5:30 PM (CST). You can also learn more about WalzCraft by visiting our website at **WalzCraft.com**.

Again, **“Thank You for your Loyalty towards WalzCraft”**. We consider it a privilege to be of service to you!

Sincerely,

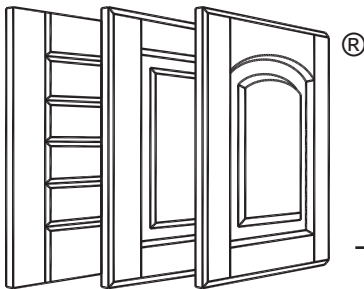

Richard A. Walz
Owner

Bradley J. Walz
Co-Owner

— “Where Custom Made Quality Begins” ® —



Product Specifications Catalog
Contact Information and Catalog "Navigation"

Customer Number

Your WalzCraft Customer Number is: #
(Please write your Customer # here)

- You will be assigned a WalzCraft Customer Number after your first contact with us.
A Customer Number:
- Provides quick and easy access to your customer information in our system.
- Ensures accuracy in the entry of quotes and orders by requiring your Customer Number on order forms.
- Ensures accuracy when posting payments to your account by noting your Customer Number on your payment stub & check.
As a quick reference, we have provided a space above to document your Customer Number.
Please use your Customer Number when placing an order, calling WalzCraft to inquire about the status of an existing order, or making a payment on an invoice.
A Customer Number does not imply that credit terms have been approved.

Phone Numbers

Customer Support Telephone Number (M-F, 6:00am - 5:30pm, CST)..... 1-800-237-1326
Customer Support Fax (24 Hour)..... 1-608-781-3667
Accounting Fax/"CHAX" Check Fax (24 Hour)..... 1-608-783-0926

Email Addresses

To Place Orders orderdept@WalzCraft.com
For Product and Catalog Questions..... customersupport@WalzCraft.com
For Accounting Questions..... accountingdept@WalzCraft.com

Websites

Website (Main)..... http://www.WalzCraft.com
Website (Cabinet Refacing Training)..... http://www.RefacingTraining.com

Mailing and Shipping Information

Mail to: WalzCraft
P.O. Box 1748
La Crosse, WI 54602-1748

Ship to: WalzCraft
2600 Hemstock Street
La Crosse, WI 54603-2349

How to Navigate this Catalog - Table of Contents

The products and options contained within this catalog have been categorized and divided into General Chapters. Each Chapter has then been divided into Sections. These Sections can then have multiple Pages associated with the product(s) contained within them. We have developed our page numbering system based on these divisions.

- Table of Contents: Immediately following "How to Navigate this Catalog" is the Master Table of Contents, which lists all of our Chapters and the individual Sections contained within those Chapters. We have also provided an additional Table of Contents at the beginning of each Chapter, which is specific to that Chapter only.

Master Table of Contents

Table with 2 columns: Section Name and Page Number. Includes Introduction, General Information, Cabinet Door & Drawer Front Options, and Profile Options.

Chapter Table of Contents

Table with 2 columns: Section Name and Page Number. Includes Cabinet Door & Drawer Front Options, Tenon - Raised Panel, and Tenon - 1/4" Flat Panel.



Page Headers and Page Numbers

The products and options contained within this catalog have been categorized and divided into General Chapters. Each Chapter has then been divided into Sections. These Sections can then have multiple Pages associated with the product(s) contained within them.

- Page Header: The Page Header at the top of each page within the Sections will always tell you what Chapter (Black Box) and Section (Gray Box) you are in.
• Page Numbers: Page #'s will always be found in the bottom corner of each page and will denote the Chapter, Section and Page #.

Page Header and Page Numbers examples. Includes a diagram of a cabinet door with callouts for 'Denotes which Chapter & Section you are currently in' and 'Denotes Chapter B, Section 1, Page 2'. Shows product details for various styles and part numbers.

Product Notes Tables

- Product Notes Tables: Towards the end of each Section you will find a Notes Table with important information regarding the product(s) within that Section. Please note that all pricing can be found in our current Wholesale Pricing Catalog which is now a separate publication.

Ordering & Pricing Notes: 'Traditional' Mortise & Tenon Raised Panel Door and Drawer Fronts

Ordering Guidelines table with 2 rows: 1 Order Forms (Please use Door and/or Drawer Front Order Forms (E-Z Forms #2 and #3).) and 1 Pricing (Please see Section B.1 of our current Wholesale Pricing Catalog.)

Quick Indexes

- Quick Indexes: Finally, at the end of the specifications catalog we have provided two types of Quick Indexes. The first is our Product # Index which lists many of our products by Style # or Part # and the page(s) they can be found on.

Product # Quick Index and Alphabetical Quick Index. Includes tables for 'Quick Index Options', 'By Product / Item #', and 'Alphabetical by Product Name'. Contains callouts explaining how to use the indices to find product information.

General Information	A
Orders, Quotes & Remakes.....	A.1
Pricing & Payments	A.2
Packaging & Shipping /Handling.....	A.3
Typical Construction & Product Specifications.....	A.4
Product & Part Sizes	A.5
Finishes & Sanding.....	A.6
Custom Products	A.7
Warranties	A.8

Cabinet Door & Drawer Front Options	B
Traditional Mortise & Tenon - Raised Panel	B.1
Quarter, Half Circle & Gothic - Raised Panel.....	B.2
Traditional Mortise & Tenon - ¼" Flat Panel	B.3
Quarter, Half Circle & Gothic - ¼" Flat Panel.....	B.4
Mitered (<i>Mitre</i>) Mortise & Tenon - Raised Panel.....	B.5
Mitered (<i>Mitre</i>) Mortise & Tenon - ¼" Flat Panel.....	B.6
French Miter Mortise & Tenon - Raised & ¼" Flat Panel.....	B.7
Adventure Series - Raised & ¼" Flat Panel.....	B.7
No-Panel Cut (NPC) Frame Only Doors	B.8
Contemporary	B.9
Veneered & Edgebanded - Standard Veneer	B.10
Veneered & Edgebanded - Reconstituted Veneer	B.11
Frame Only & Mullion Lite Patterns.....	B.12
Combination Frame & Panel	B.13
Louver /Wood Shutters - Operable & Non-Operable.....	B.14
Louver /Wood Shutters - Closed (<i>No Air Flow</i>)	B.15
Continuous Bead Applied Molding Doors.....	B.15
Drawer Fronts - Slab & RP (Raised Panel).....	B.16
Drawer Fronts - Molded.....	B.17
Onlay Frames	B.18
Pyramid Panel Doors & Drawer Fronts	B.19

Passageway Door Options	C
Raised Panel Doors (<i>Interior Use Only</i>).....	C.1
¼" Flat Panel Doors (<i>Interior Use Only</i>).....	C.2

Convex-Concave Options	D
Convex / Concave Products & Glossary of Terms	D.1
Convex Ordering Information.....	D.2
Concave Ordering Information	D.3
Convex / Concave Crown Molding Options.....	D.4
Convex / Concave - General Information	D.5

Profile Options	E
Stile & Rail - Traditional Mortise & Tenon Joinery	E.1
Stile & Rail - Traditional M/T Joinery - Mirror Joints	E.2
Stile & Rail - Traditional M/T Joinery - Old World.....	E.3
Stile & Rail - Inside Edge Applied Molding.....	E.4
Stile & Rail - Shelf Applied Molding	E.5
Stile & Rail - Face Applied Molding.....	E.6
Applied Molding - Corner Blocks	E.7
Applied Molding - Outsourced Moldings.....	E.8
Stile & Rail - Mitered (<i>Mitre</i>) - MP600/MP6000 Series	E.9
Stile & Rail - Mitered (<i>Mitre</i>) - MP700 Series	E.10
Stile & Rail - Mitered (<i>Mitre</i>) - MP900 Series - Old World.....	E.11
Center Panel - Standard Raised/Recessed Raised Panel	E.12
Center Panel - Reversed Solid Center Panel (RVSCP-PR324).....	E.13
Center Panel - Old World Raised	E.14
Outside Edge - Standard	E.15
Outside Edge - Applied Molding	E.16
Outside Edge - Molder Edges for MP600/MP6000.....	See E.9
MDF 1-Piece/3D Laminate (RTF) Profiles.....	See V.1

Functional Options	F
Hinge Boring.....	F.1
Miscellaneous Joinery (MJ).....	F.2
Joint Assembly Methods (JAM)	F.3
Half Lap Options.....	F.4
Additional Outside Edge.....	F.5
Lazy Susan Corner Door Joints	F.6
Hand Pull & Finger Pull Rout	F.7
Finger Pull Moldings - Applied	F.8
Drawer Front Scoops	F.9

Design Options	G
Designer Glass	G.1
Leaded Glass	G.2
Glass Shelves	G.3
Wire Mesh.....	G.4
Cane/Wicker Center Panels.....	G.5
Lattice Center Panel & Lattice Sheet Stock.....	G.6
Center Panel Face Rout (CPFR)	G.7
Center Panel Face Rout Patterns.....	G.8
Panel Design Patterns	G.9
Drawer Front Face Rout (DFFR).....	G.10
Stile & Rail Face Rout (SRFR).....	G.11
Decorative Inserts	G.12
Outside Radius Corners	G.13
Distressing.....	G.14
Laser Engraving.....	G.15
Profiled Stock.....	G.16
Grain and Color Coordination - Veneer	G.17
Square / Tapered Foot Options.....	G.18
Faux Cut.....	G.19
Accent Recessed Applied Molding.....	G.20



Drawer Box Options	H
Drawer Box Style 100HB - Half Blind Dovetail	H.1
Drawer Box Style 100F/T - Full/Through Dovetail.....	H.2
Drawer Box Style 100FR - French Dovetail.....	H.3
Drawer Box Style 100DW - Doweled (Plywood)	H.4
Drawer Box Style 100DW - Doweled (Melamine)	H.5
Drawer Box Style 100NL - Nailed	H.6
Drawer Box Bottom Panels	H.7
Drawer Box Options - Drawer Slide Notching.....	H.8
Drawer Box Options - Shaped Side Patterns	H.9
Drawer Box Options - Scoop Fronts.....	H.10
Drawer Box Options - Ears.....	H.11
Drawer Box Options - Hanging File Slots.....	H.12
Drawer Box Options - Accented Top Edge.....	H.13
Drawer Box Options - Laser Engraving	H.14
Drawer Box Options - Bread Box Slideback Lid	H.15
Drawer Box Options - Notched Patterns	H.16
Drawer Box Options - Curved Front Patterns.....	H.17
Drawer Box Options - Inside Corner Patterns	H.18
Drawer Box Options - Drawer Slide Blocking.....	H.19
Drawer Box Options - No Glue-Up Option.....	H.20
Drawer Box Organizer Inserts (DBOI).....	H.21
Drawer Box Side Material	H.22
Drawer Box Divider Stock.....	H.23

Hardware Options	I
Hinges by Salice	I.1
Drawer Slides by Salice	I.2
Hardware Screws & Miscellaneous	I.3
Drawer Slides - Side Mount.....	I.4
blum COMPACT Face Frame Hinges	I.5
blum COMPACT BLUMOTION Face Frame Hinges.....	I.6
blum CLIP top Long Arm Hinges	I.7
blum CLIP top BLUMOTION Long Arm Hinges.....	I.8
blum TANDEM plus BLUMOTION Drawer Slides	I.9

Face Frame Options	J
Face Frame Stock - Square, Beveled, Beaded	J.1
Assembled & Ready to Assemble (RTA) Face Frames	J.2
Face Frame Options - Square/Tapered Foot.....	J.3
Face Frame Options - Miscellaneous Joinery	J.4
Face Frame Options - Beaded Applied Molding	J.5
Face Frame Options - Inset/Prefit Doors	J.6
Face Frame Options - Blind Corner Extension.....	J.7
Cabinet Fillers - Square, Beaded	J.8

Sheet Stock Options	K
Veneers, Plywood & MDF.....	K.1
Reconstituted (Composite) Veneer.....	K.2
Custom Pressed.....	K.3
Veneer Edgebanding	K.4
Surfaced/Rough Lumber	K.5

Cabinet Box Component Options	L
Basic Components	L.1
Complex Components.....	L.2

Cabinet Accessory Options	M
Valances - Upper Cabinet & Toe Kick	M.1
Valances - Raised Panel Arch - Mortise & Tenon.....	M.2
Valances - ¼" Flat Panel Arch - Mortise & Tenon.....	M.3
Keystone	M.4
Knick Knack Shelves.....	M.5
Shelf Support Assemblies	M.6
Cabinet Hutch End Panels	M.7
Wine Racks	M.8
Plate Display	M.9
Appliance Garage Kits.....	M.10
Tambour Door & Track System.....	M.11
Butcher Block (Face Glued Staves).....	M.12
Cutting Boards	M.13
Bread Boards.....	M.14
Appliance Panels.....	M.15
Glued-Up Panels (GUP) & Center Panels Only (CPO).....	M.16
Floating Shelves.....	M.17

Molding Options	N
Crown Molding	N.1
Refacing Molding	N.2
Corner & Scribe Molding	N.3
Base & Casing Molding.....	N.4
Applied Molding	N.5
Mullion Stock Molding.....	N.6
Column Molding.....	N.7
Wainscot Molding.....	N.8
Miscellaneous Molding.....	N.9
Arched Canopy Styles / Molding.....	N.10
Precision Molded Wood Flooring	N.11
Molding Notes	N.12
Outsourced Molding	N.13

Accent Component Options	O
Collections	O.1
Corbels	O.2
Legs/Posts - Stock Sizes.....	O.3
Legs/Posts - Custom Sizes	O.4
Create-A-Molding.....	O.5
Create-A-Column.....	O.6
Rosettes	O.7
Fluted Molding.....	O.8
Column Wraps - Square	O.9
Plinth Blocks.....	O.10
Bun Feet.....	O.11
Cabinet Feet - Corner.....	O.12
Outlet & Vent Covers.....	O.13

Range Hood Options	P
Chimney Style Hoods	P.1
Wall Mount Style Hoods.....	P.2
Island Style Hoods	P.3
Curved Style Hoods	P.4
Mantel Style Hoods.....	P.5
Hearth Style Hoods.....	P.6
Ventilation Units (Liners & Blowers).....	P.7
General Information	P.7

Wainscot Options	Q
Raised Panel.....	Q.1
¼" Flat Panel.....	Q.2
Wall Wainscot Kit Components	Q.3
Tongue & Groove	Q.4

Finish Options	R
Finishing Methods - Stain.....	R.1
Finishing Methods - SolidTone® (Painted)	R.2
Finishing Methods - Glaze.....	R.3
Rub Through Options.....	R.4
Melamine/Laminate/PVC Edgebanding Matches	R.5

Wood Species Options	S
Wood Species/Grade Descriptions - Solid Wood.....	S.1
Wood Species/Grade Descriptions - Veneer.....	S.2
Miscellaneous Notes	S.3

Dealer Aid Options	T
Color Blocks	T.1
Product Samples.....	T.2
Wall Mounted Sample Door Display Kit.....	T.3
Door/Drawer Front Carrying Cases	T.4
Customizable Marketing Cards.....	T.5

Cabinet Refacing Options	U
Cabinet Refacing Training	U.1
WalzCraft Custom Refacing Hand Tools.....	U.2

Composite Product Options	V
MDF 1-Piece/3D Laminate (RTF)	V.1
Decorative Laminate Veneer (DLV)	V.2
High Pressure Laminate (HPL).....	V.3
Melamine	V.4

“Abbreviations”	ZY
Abbreviation Descriptions	ZY.1

Quick Index Options	ZZ
By Product/Item #	ZZ.1
Alphabetical by Product Name	ZZ.2

Tabbing of Catalog Pages

The WalzCraft Product Specifications Catalog covers a wide array of products. Due to the catalog size we are sometimes asked by customers if we have considered “tabbing” the sections for faster access to information. We have investigated this, but have found that trying to tab the catalog to meet the different needs of all our customers would result in an extremely high number of tabs. The fact that every customer has different ideas and thoughts about what he or she would like to see tabbed has led us to the following solution that is already in use by some of our customers.

- In most cases, a relatively small number of tabs on the pages that you use most often can save time when working with our catalogs.
- Some of our customers are using a variety of standard off the shelf Self Adhesive Index Tabs to tab the catalog for their own specific interests.
- In addition, since the Index Tabs are available in colors, tabbing the appropriate Price Catalog pages in the same color as the Specification Catalog makes looking up prices easier.

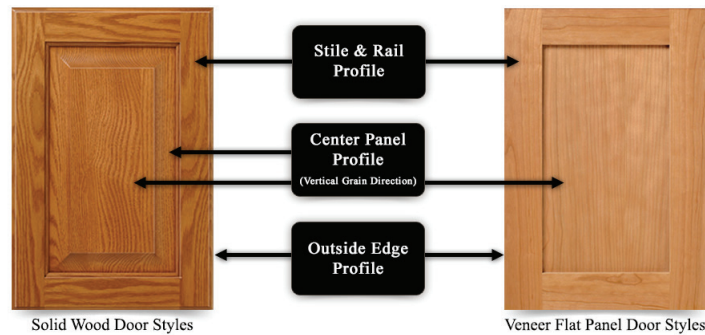



Table of Contents

Section #	Section Name /Contents	Page #
A.1	Orders, Quotes & Remakes	A.1.4
	◦ One Door Orders Welcome	A.1.4
	◦ Ordering	A.1.4
	◦ E•Z Order Forms	A.1.4
	◦ Metric Orders Welcome/Preferred	A.1.4
	◦ Emailing Documents and Other Information to WalzCraft	A.1.4
	◦ Measurements	A.1.4
	◦ Quotes	A.1.4
	◦ Order Changes & Change Charges	A.1.4
	◦ Remakes	A.1.5
	◦ Production Scheduling	A.1.5
	◦ Estimated Ship Dates	A.1.5
	◦ Order Acknowledgments	A.1.5
	◦ Order Price Acknowledgments	A.1.5
	◦ Submit Images of Your Completed Projects	A.1.5
	◦ Inventory Reduction (IR) Specials	A.1.5
◦ Customer Generated Reference Number (CGR#)	A.1.6	
A.2	Pricing & Payments	A.2.1
	◦ Credit Checks & Payment Terms	A.2.1
	◦ Payment Policy & Payment Methods	A.2.1
	◦ Service Charges	A.2.1
	◦ CHAX (Check Fax) Payment Method	A.2.1
	◦ Wholesale Pricing Catalog	A.2.2
	◦ Wholesale Pricing Method - Unfinished Products	A.2.2
	◦ Price Changes	A.2.2
	◦ Material Thickness	A.2.2
	◦ Calculating Square Footage	A.2.2
A.3	Packaging & Shipping/Handling	A.3.1
	◦ Packaging Methods	A.3.1
	◦ Shipping/Handling	A.3.2
	◦ Packaging 96" or Longer	A.3.2
	◦ Common Carrier Shipments	A.3.2
	◦ Pick Up/Will Call	A.3.3
	◦ Shipping Arranged by Customer	A.3.3
	◦ Canadian Shipments	A.3.3
	◦ Shipping Damage/Damage Claims	A.3.3
	◦ Hazardous Material Packaging & Shipping/Handling	A.3.4
	◦ Return/Recycle Drawer Box H-Clips	A.3.5
	◦ Return/Recycle Pallets	A.3.5
	◦ Recycle Foam Packaging	A.3.5
◦ Return/Recycle Packaging Corners	A.3.5	

General Information



Solid Wood Door Styles

Veneer Flat Panel Door Styles

Table of Contents...continued

Section #	Section Name/Contents	Page #
A.4	Typical Construction & Product Specifications	A.4.1
	◦ Door & Drawer Front Parts/Grain Direction	A.4.1
	◦ ¾" - "Traditional" Door Construction (Typical Construction)	A.4.2
	◦ 1" - "Traditional" Door Construction (Typical Construction)	A.4.3
	◦ 1" - "Old World" Door Construction (Typical Construction)	A.4.4
	◦ Center Rail Placement	A.4.5
	◦ Panel Matching	A.4.5
	◦ Flat Panel Door "Look"	A.4.5
	◦ Door Styles Using Corner Blocks	A.4.5
	◦ Pinless Door Construction	A.4.5
	◦ Products for Exterior Use	A.4.5
	◦ Ready to Assemble (RTA) Products	A.4.5
	◦ Pressure Sensitive Products	A.4.5
	◦ "Green" & Environmental Products	A.4.5
	◦ Fire Rating	A.4.5
◦ Technical Information & Product Specifications Disclaimer	A.4.5	
◦ Signature Series Key	A.4.6	
◦ Moisture Content of Wood	A.4.7	
A.5	Product & Part Sizes	A.5.1
	◦ Standard & Non-Standard Part Sizes	A.5.1
	◦ Minimum Size Doors	A.5.1
	◦ Reducing Center Panel Profile Reveals	A.5.1
	◦ Left & Right Door Style #'s 2100, 2121 and 3131	A.5.1
	◦ Minimum Stile/Rail Part Sizes	A.5.2
	◦ Veneered/Laminated Product Thickness Tolerances	A.5.2
	◦ Oversized Doors	A.5.2
	◦ Oversized Panels	A.5.2
	◦ Assembled Products Over 50"W x 50"H	A.5.2
◦ Size (W x H) Tolerances	A.5.2	
A.6	Finishes and Sanding	A.6.1
	◦ Natural & Light Stain Colors	A.6.1
	◦ Spray-No-Wipe Stains	A.6.1
	◦ Engineered Stain/Paint Relief Cut	A.6.1
	◦ Painted Products (SolidTone®)	A.6.1
◦ Final Finish Sanding (Prior to Finishing)	A.6.1	

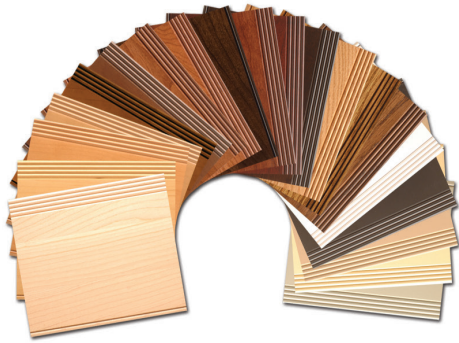

Starter Variety Pack

Order Part # 165243

Consists of a variety of the most popular Wood Species, Stain & SolidTone® Color & Glaze combinations.



Glazed Color Block Set

Order Part # 148870

Consists of a variety of the most popular Wood Species, Stain & SolidTone® Color & Glaze combinations and a "Rub Through" sample.

Table of Contents...continued

Section #	Section Name /Contents	Page #
A.7	Custom Products	A.7.1
	◦ Configuration = Customization	A.7.1
	◦ Custom Engineered Products	A.7.1
	◦ Custom Engineered Profiles	A.7.1
	◦ Customer Requested Drawings	A.7.1
	◦ New Products	A.7.1
	◦ Refacing Products	A.7.2
	◦ Redooring/Refronting	A.7.2
	◦ Kitchen & Bathroom Standards	A.7.2
	◦ Outsourced Products	A.7.2
A.8	Warranties	A.8.1
	◦ General Warranty	A.8.1
	◦ Warranty on Door Joints	A.8.1
	◦ Warranty on Glued Up Panel Expansion/Contraction	A.8.1
	◦ Warranty on Warping	A.8.1
	◦ Warranty on Bowing	A.8.2
	◦ Warranty on Twisting	A.8.2
	◦ Warranty on Convex/Concave Doors & Drawer Fronts	A.8.2
	◦ Warranty on Passageway Doors	A.8.2
	◦ Warranty on Solid Wood Slabs with Applied Molding	A.8.2
	◦ Warranty on Applied Molding Attached by Others	A.8.2
	◦ Warranty on Solid Wood Moldings	A.8.2
	◦ Warranty on Veneered Products	A.8.2
	◦ Warranty on Unfinished Products	A.8.3
	◦ Warranty on Product Finished by WalzCraft	A.8.3
	◦ Warranty on Product Finished by Others	A.8.3
	◦ Warranty on SolidTone® Products	A.8.3
	◦ Warranty on 3D Laminate (RTF) Products	A.8.3
	◦ Warranty on Add-On Orders	A.8.3
	◦ No Warranty on Products Used Outdoors	A.8.3
	◦ Feedback Welcome	A.8.4
◦ Contact Us	A.8.4	
◦ Catalog Copyright Date	A.8.4	

General Information

One Door Orders Welcome

WalzCraft is oriented toward serving small to medium-sized companies and accepts orders of any quantity, even 1 door.

Ordering

- **Verbal phone orders are welcome!!**
 - By telephone during normal business hours at 1-800-237-1326
 - Monday through Friday, 6:00AM - 5:30PM (CST)
- **Fax:** 24 hours a day, seven days a week at 1-608-781-3667.
- **Email: orderdept@WalzCraft.com**
 - **Email "Read Receipt"**
 - Should you have a concern with whether or not WalzCraft has received your email, when you send your email, we ask that you please also request an automatic "Read Receipt".
 - A "Read Receipt" is a notification/message that the system sends back to you when a recipient opens your email. When requested you will automatically receive an instant read receipt as your email is opened, letting you know that it has arrived here at WalzCraft safely.
 - If you use **Microsoft Outlook** as your email application simply go to your Outlook "Options" tab and select "Request Read Receipt".
 - Most other email applications (ie: Yahoo, Hotmail, Gmail, AOL & iPhones) also provide the option or an application that can be used to request a Read Receipt.
- **U.S. Mail:** "See Remit To" address listed under "Important Contact Information" in the introduction of this catalog.
 - Note:* 1) **Orders received after 4:30PM Central Standard Time** will be processed on the next working day.
 - 2) **Orders lacking information** required for processing will be withheld from the production schedule until specifications are clarified.

Whenever possible, please submit your order on our WalzCraft E-Z Order Forms.

E-Z Order Forms

- **For the most up to date E-Z Order Forms:**
 - Visit our website at www.WalzCraft.com.
 - View our **E-Z Order Form FAQ** page to assist you in using WalzCraft **E-Z Order Forms**.
- **E-Z Order Forms - Electronic Copy:**
 - The **E-Z Interactive Order Form** is designed to be filled out on your computer screen and emailed to our order department.
 - *This is WalzCraft's preferred method of receiving orders.*
- **E-Z Order Forms - Paper Copy:**
 - **E-Z Order Forms** are available in a PDF format so you can print, fill out by hand and fax or email to our Order Department.

Metric Orders Preferred / Welcome

- WalzCraft's entire manufacturing operation uses millimeters to calculate component part sizes.
- Millimeter dimensions can be ordered out to one decimal point.
 - Inch dimensions can be ordered in fractions to the nearest 1/32" or the five decimal point equivalent of 1/32".
 - A metric tape measure should be used when measuring in millimeters. If this is not an option and you need to convert your dimensions, please refer to the **Fractions Conversion Chart** on our website: **Resources > Technical Information > Industry Tools**.
 - **1 Inch = 25.4 mm**

Emailing Documents and Other Information To WalzCraft

- If you need to email documents of any sort to WalzCraft, the best file format to use is **.pdf**, short for Portable Document Format. The next best would be **.jpg**, short for JPEG, named after the Joint Photographic Experts Group who created the standard.
- WalzCraft will attempt to work with any files that you email to us, but some formats, like **.xls** and **.zip**, usually experience delays in the email process as they will be quarantined and examined before being delivered to the recipient here at WalzCraft.
- Some WalzCraft products may require CAD files or Image/Graphics files be sent. In these cases, the following file formats should be used:
 - **CAD Files**
 - **.dwg** (Drawing)
 - **.dxf** (Drawing Exchange Format)
 - **Images/Graphics files for Laser Engraving**
 - **.eps** (Encapsulated PostScript)
 - **.jpg** (Joint Photographic Experts Group) - at least 600 dpi.
 - **.tif** (Tagged Image File) - at least 600 dpi.
 - **Image files for Customizable Marketing Cards**
 - **.jpg** (Joint Photographic Experts Group) - at least 300 dpi.
 - **.tif** (Tagged Image File) - at least 300 dpi.

Measurements

When communicating dimensions, ***no*** adjustment is made to the size you provide. To ensure consistency order ***exact*** sizes, ***using this format***, on the order form.

- Doors.....**Width then Height**
- Drawer Fronts.....**Width then Height**
- Drawer Boxes.....**Width then Depth followed by Height**

Quotes

To request a quote prior to placing an order:

- Mark the **Quote Only** box on the **WalzCraft E-Z Order Form Cover Sheet**.
- Freight Charges and the Taxes applied to those charges are not included.
- Quotes will be honored up to 30 calendar days from the date the quote was forwarded to you.
 - Quotes beyond 30 days **may** be valid provided that no pricing has changed since the initial quote date. (Estimated Wait-Times / Ship dates are subject to change based on current production demands.)

Order Changes & Change Charges

- Please see **Section A.1** of our current **Wholesale Pricing Catalog** for change charges.
- **Once in production, Wait-Times may be compromised.**
- Due to "**Short**" **Wait-Times** your order could go into production the same day it is received. Changes can be accommodated up until the manufacturing paperwork is generated.
- **If parts cannot be modified to meet your needs**, you are **required to take delivery** of all original items and will be billed at their normal cost.
 - We will expedite orders for these replacements, and apply a 30% discount to their cost.

Remakes

If WalzCraft makes a mistake on your order:

- We will replace the items immediately by producing them on an expedited production schedule, at **no additional charge**.
- Replacement items are shipped via the shipping method originally used. In cases where common carrier is not necessitated by size or quantity, replacement items will ship via small package carrier.

Production Scheduling

When placing an order with WalzCraft, your order will be produced on our **(SL) Standard Wait-Time Production Schedule**. In the event that our **“Standard Wait-Time” Production Schedule** does not satisfy your immediate needs, our **(EX) Expedited Wait-Time Production Schedule** may be an option.

- **(SL) “Standard Wait-Time” Schedule**
 - Refers to the number of days it takes to **“manufacture”** your custom made products through our normal production schedule, which is dictated by daily order volume and product complexity.
- **(EX) “Expedited Wait-Time” Schedule**
 - In the event that our **(SL) Standard Wait-Time Schedule** does not satisfy your needs, the **(EX) Wait-Time Schedule** may be an option.
 - Requests to **“Expedite”** an order are individually reviewed by our Production Scheduler and Plant Head Coach to determine the Wait-Time based on complexity of the project and daily production schedules. You may be asked to complete a short questionnaire to explain your need to expedite the order. This will help us with scheduling your project to the best of our abilities. **(EX) Wait-Times** can vary, as does each project and situation.
- **Expedited Orders are subject to a 30% - 50% upcharge.**
- Processing an **Expedited Order** **does not** in any way indicate that you need to expedite the shipping method.
 - You must indicate the need to rush the shipping method (ie: UPS - Next Day Air) in the **“Shipping Preference”** area on the **WalzCraft E•Z Order Form Cover Sheet**.
- **To indicate the production schedule that best suits your needs, check the appropriate box on the WalzCraft E•Z Order Form Cover Sheet.**

Production Schedule * **SL** **EX**

- **If neither box is checked on the WalzCraft E•Z Order Form Cover Sheet, your order will be produced on our (SL) Standard Wait-Time schedule.**
- Orders containing product with varying Wait-Times will be produced on the same production schedule as the product with the longest Wait-Time on the order.
- Wait-Times for products, such as complex wainscots, and parts with radii, angles or odd shapes, **cannot be established** until all engineering details are determined and agreed upon by WalzCraft and the customer.
 - Once questions are answered and manufacturing guidelines are defined, our production scheduling team can estimate the Wait-Time and schedule your project.

Orders “lacking” information required for processing will not be scheduled until specifications are clarified.

Estimated Ship Dates

- Estimated Ship dates are printed in the Order Acknowledgment title block at the top of the document. Our goal is to produce your order within this date range.
- Estimated Ship dates are not guaranteed, and may vary due to incoming order volume, material availability, capacity or other unforeseen factors.
- Please allow adequate time for delivery when scheduling installation.

Order Acknowledgments

- Order acknowledgments on all orders are routinely emailed, faxed or mailed, based on your preferences.
- For email and fax customers, if you haven’t received an Order Acknowledgment or some kind of verbal communication from a WalzCraft Team Member within 24 hours of placing an order, please call our Customer Support Team to confirm that we have received the order.
- Please review your Order Acknowledgment very carefully and notify our staff immediately of any discrepancies so appropriate corrections can be made prior to going into production.
- Please note that most **“Basic”** orders go into production within a matter of hours after receipt.

Charges will be incurred, for changes requested, after an order is released for production.

Order Price Acknowledgments

To request an Order Price Acknowledgment when placing an order:

- Mark the box on the **WalzCraft E•Z Order Form Cover Sheet** that says:
Proceed with Order/Send Order Price Acknowledgment
- You can also request an **Order Price Acknowledgment** for orders currently in production. Simply contact our Customer Support Team.
- Freight charges & applicable sales taxes are not included.

Submit Images of Your Completed Projects

WalzCraft’s Marketing Team is always looking for quality installation images that showcase our products and your craftsmanship. We welcome you to submit images of your work. Please visit our website at www.WalzCraft.com/showcase for more information.

Inventory Reduction (IR) Specials

From time to time, as inventory levels dictate, WalzCraft would like to offer our customers a discount if they order products in a specific wood species and grade. Due to fluctuations in our inventory, **IR Specials** may start and end unexpectedly, so for up to date information on current **IR Specials**, please visit our website at WalzCraft.com. If considering an **IR Special**, the most common grade to expect is Value / Budget Grade.

► **For PRICING** ► See Section **A.1** in our current Wholesale Pricing Catalog.

Customer Generated Reference Number

The **Customer Generated Reference Number (CGR#)** column provides an area on our WalzCraft *E•Z Order Forms* where you can designate your own reference number to help you identify the items being ordered in an effort to aid you in streamlining the manufacturing process on your end. We encourage the use of WalzCraft *E•Z Order Forms* when **CGR#s** are being used.

- We can accommodate up to 8 characters for your reference #.
- Available when using most "Advanced" WalzCraft *E•Z Order Forms*.
- Your **CGR#** will print on the WalzCraft paperwork you receive:
 - Order Acknowledgments & Order Price Acknowledgments
 - Price Quotes
 - Packing Lists
 - Invoices
 - Product Labels

Reference Number Example										
ions	Customer Generated Ref # (CGR#)									
	3	1	L							Room #3 Cabinet #1 Left Door
	5	1	0	R						Room #5 Cabinet #10 Right Door

- Pre-finished product is wrapped in microfoam/kraft paper, and the label with the **CGR#** is affixed to the microfoam/kraft paper.
- Drawer Box **CGR#** labels will be affixed to the underside of the drawer box bottom.
- For unfinished product, individual items will have the usable **CGR#** label/backer paper loosely affixed to the back of the product allowing you to place the label as needed after finishing.



WalzCraft®

PO Box 1748, La Crosse, WI 54602-1748
2600 Hemstock St, La Crosse, WI 54603-2349

"Where Custom Made Quality Begins"®

1-800-237-1326 24 Hour Fax: 1-608-781-3667 WalzCraft.com

E•Z Form # 2.1

Page 3 of 3

"Advanced" Door Order Form continued page 2

WCI CO# _____

Essential Info

Customer # _____

Company Name _____

Job Name / PO # _____

Packaging Method

Best Way I prefer Packaging Method #

WalzCraft will choose a Method

*Area designated for a
Customer Generated
Reference # (CGR#)*

WCI only	QTY	Door Style	Order Exact Door WIDTH	Order Exact Door HEIGHT	Additional OSE OSE # Location	Hinge Bore	Finger Pull	Half Lap 01 02	Frame Only	Mullion Lite Pattern or LP Option	# of lites	Std or TL	Special Instructions	Customer Generated Ref # (CGR#)

► For PRICING ► See Section A.1 in our current Wholesale Pricing Catalog.



Credit Checks & Payment Terms

- Your Social Security # will be requested for a "Credit Check".
- A "Credit Check" will be run prior to processing your "First Order" with WalzCraft or upon reactivation of a "Dormant Account". A "Dormant Account" is an account that has gone 12 consecutive months without placing a bona fide order with WalzCraft.
- If you request that a credit check "**not**" be run, the **only** payment options available are Prepaid Credit Card, or Prepaid Certified Check or Money Order.

Payment Policy & Payment Methods

- All payments must be paid in U.S. Dollars only.
- Due to custom-built sizes and specifications, we require full payment upon delivery.
- **Prepayment may also be required prior to scheduling an order; due to the cost of the order, or due to a less than desirable credit report. You will be notified if prepayment is required.**
- **When paying with a Debit Card, funds are charged as soon as we receive your approval to proceed with the order. This process removes those funds from your available balance immediately.**
- Payment options available when **prepayment is required**:
 - Credit Card
 - Visa, MasterCard, Discover or American Express
 - Debit Card
 - Visa, MasterCard
 - Certified Check or Money Order only
- Payment options available when **prepayment is not required**:
 - Company Check
 - Credit Card
 - Visa, MasterCard, Discover or American Express
 - Debit Card
 - Visa, MasterCard
 - COD, Certified Check or Money Order only
 - COD, Company Check
- **Funds will be authorized**, prior to charging to a credit card.
- When charging to a credit card, **you** have 30 days to make a payment to your credit card company, and need **not** be present to pay for a COD when product is delivered. (This does not apply to shipments via common carrier.)
- You may also request an application for Net 30 Day terms by contacting our Accounting Support Team at: 1-800-237-1326.
 - A good business relationship is determined by your purchases and payment history. Based on this, open account references and credit worthiness, Net 30 Day terms may be granted.

** Please allow a few weeks to process your credit application. Upon completion a response will be mailed to you. Net 30 Day terms require payment to be received and posted to your account within 30 days of the invoice date; the invoice date should not be confused with the statement date.*

Service Charges

- Are posted to account, 31 days after original invoice date.
- Are billed by separate invoice.
- Will appear on monthly statement.
- Are **not** negotiable.

"CHAX" (Check Fax) Payment Method

- WalzCraft is also set up to accept your company check payments through our CHAX program. The CHAX Payment Method allows you to fax your check to us for payment rather than mailing it. WalzCraft simply enters the pertinent information from your faxed check into our CHAX software program. That check can then be scanned into WalzCraft's Check Deposit Scanner, which generates a check at our location. **Please see below for instructions or call our Accounting Team to have CHAX instructions sent to you.**
- Can be utilized by anyone making payment by means of a company check.
- **Benefits:**
 - Orders can now be released for production the same day.
 - Finance charges can be avoided.
 - No risk of checks getting lost in the mail.
 - Eliminate Express Mail & Overnight Fees.
- **Here's how it works . . .**
 - Step 1)** You write your check out to WalzCraft, just as you have always done.
 - Step 2)** You sign your check.
 - Step 3)** You fax your signed check to **1-608-783-0926**;
Attention: WalzCraft Accounting Team
Note: WalzCraft, as a company, prefers that you **do not** scan your check and email to us due to **Internet Security**; but if you choose to do so, you may email to: accountingdept@walzcraft.com, at your own risk.
 - Step 4)** You retain your original check for your records on your end, but mark as "**CHAXED to WalzCraft**".
 - Step 5)** WalzCraft enters the pertinent information from your faxed check into our "**CHAX**" Software Program.
 - Step 6)** The "**CHAX**" software generates a check on our end that can be scanned into WalzCraft's Check Deposit Scanner.
 - Step 7)** WalzCraft will fax you a receipt when the "**CHAX**" payment is deposited.
 - Step 8) Transaction is complete.**
- **Please note:**
This payment option **is not available** to anyone whose terms are currently set up as "Prepay / Credit Card", "Prepay / Certified Check or Money Order", or "Certified Check or Money Order Upon Delivery".

► **For PRICING** ► See Section A.1 in our current Wholesale Pricing Catalog.

Wholesale Pricing Catalog

All pricing information is printed in WalzCraft's "Wholesale Pricing Catalog", which is now a separate publication from this **Product Specifications Catalog**. Please reference WalzCraft's "Wholesale Pricing Catalog" for all pricing notes, pricing examples & formulas and price grids.

Pricing information for products and options contained within the **Wholesale Pricing Catalog** have been categorized and divided into general **Chapters**. The **Chapters** and **Sections** correspond to the same Chapters and Sections within the **Product Specifications Catalog**. The page numbering system has been developed based on these divisions.

► **For PRICING** ► See Section A.1 in our current Wholesale Pricing Catalog.

You will find this banner at the bottom of most pages throughout this catalog. **This is the key to locating each Pricing Section, the Pricing Notes and Pricing Examples for products in this Product Specifications Catalog.**

Wholesale Pricing Method - Unfinished Products

- Most items are priced by the square foot. If an item is priced using a different method, it will be noted on that particular profile or in that product section.
 - **Pricing includes the cost for a center panel, stiles and rails, most outside edge profiles and finish sanding.**
- To price:**
- Select your door or drawer front style.
 - Find the Price Class printed below each style.
 - Cross reference the wood species and grade with the appropriate price class in the pricing tables found in **WalzCraft's Wholesale Pricing Catalog**.
 - Multiply the square footage of the door, by the square foot price to arrive at your wholesale cost.
 - Add charges for finishing, non-standard parts, oversized product or other options required for custom detailing as listed throughout this catalog, if appropriate.

Price Changes

- WalzCraft product pricing is subject to change without notice.
- WalzCraft reserves the right to pass along temporary and/or non-negotiable (energy/economic-related) surcharges that are assessed by our suppliers, and that cannot be predicted.
- This publication supersedes all prior technical, policy, customer support and pricing data.

Material Thickness

- WalzCraft products come in various shapes and sizes. Most wood species and grades are available in multiple thicknesses. Please refer to the individual Sections within the **Product Specifications Catalog** and **Wholesale Pricing Catalog** for thickness options and applicable charges.
- Products will finish at specified thickness. To accomplish this, WalzCraft will start with a slightly thicker material and then sand to specification.
- **Requests for special thicknesses not noted in the catalog are subject to approval and upcharges may apply. To inquire, please contact our Customer Support Team.**

Calculating Square Footage

Square footage is determined by multiplying the width of a product (in inches) by the height/length of the product (in inches) then dividing by 144.

STEP 1) **W** (in inches) x **H** (in inches) = Total sq. in.

STEP 2) Divide total square inches by 144, round off to the nearest one hundredth of a square foot.

Example: Door size is 13"W x 26"H
 13 x 26 = 338
 338 ÷ 144 = **2.35 square feet**

- Use the above formula, along with the price per square foot, when figuring the cost of your door or drawer front.
- Doors and 5-Piece drawer fronts carry a 1.25 square foot minimum per item for **pricing**.
- Slab & RP (Raised Panel) drawer fronts carry a .75 square foot minimum per item for **pricing**.
- Please do not confuse minimum square foot for pricing with the minimum size for building a product.

► **For PRICING** ► See Section A.1 in our current Wholesale Pricing Catalog.



Packaging Methods

We reserve the right to upgrade any packaging method that is deemed to be inadequate, based on shipping preference and product replacement costs.

- When packaging orders, our main objective is to ensure that products shipped from WalzCraft reach you intact.
- For packaging purposes, 3D Laminate (RTF), High Pressure Laminate (HPL), Decorative Laminate Veneer (DLV) and Melamine products are considered “**Prefinished**” products.
- We prefer to determine the “**Best Way**” to package your orders, using our preferred carriers.
 - When placing an order, please **X** the **Best Way** box in the **Packaging Method** space on the order form, and WalzCraft will make the decision for you.

Packaging Method

Best Way I prefer Packaging Method #

WalzCraft will choose a Method

- Also note if you are able to accept freight via common carrier by placing an **X** and marking **OK** in the Common Carrier space under **Shipping Preferences**.

Shipping Preference

Small Package Carrier Common Carrier Other Please list below

A. Best Way / Method B. _____ C. **OK** _____ D. Pick Up / Will Call E. _____

- WalzCraft works with preferred carriers with whom we have negotiated freight rates; furthermore, those rates are passed along to you.
- If you have any concerns with our preferred carriers, please call our Customer Support Team to discuss further.
- If you select your shipping and packaging preference, please reference the **Packaging Method** chart below to assure that the packaging method you have selected is compatible with your shipping method.
- Wainscots, oversized product or large quantities may require **PM9, PM11, PM19 or PM20**. Please note, only those items that require it will be crated. The remainder of the order will be packaged as indicated on the order form.
 - Hand Crates (**PM9**) have a maximum size of 36” x 96”. Hand crates over this limit will be priced as an Oversized Hand Crate (**PM19**).
 - Pallet Crates (**PM11**) have a maximum size of 48” x 96”. Pallet crates over this limit will be priced as an Oversized Pallet Crate (**PM20**).
- **PM16** and **PM17** are only available for Drawer Boxes with a SolidTone® finish. Drawer Boxes with a SolidTone® finish can only be packaged utilizing **PM16** and **PM17**.
- **PM18** is intended primarily for packaging sheet stock 1/8" thick or greater, but WalzCraft may also opt to use for other products when necessary.
- Please see **Section A.1** of our current **Wholesale Pricing Catalog** for Packaging Fees.

Packaging Method		Small Pkg. Carrier Unfinished	Small Pkg. Carrier Prefinished	Common Carrier Unfinished	Common Carrier Prefinished	Pickup / Will Call Unfinished	Pickup / Will Call Prefinished
PM1	Stretch Wrapped Bundles / Unprotected					X	
PM2	Microfoamed / Kraft Wrapped					X	X <i>See pg A.3.3</i>
PM3	Palletized			X		X	
PM4	Microfoamed / Kraft Wrapped & Boxed					X	X
PM5	Microfoamed / Kraft Wrapped & Palletized			X	X	X	X
PM6	Boxed & Foamed	X		X		X	
PM7	Microfoamed / Kraft Wrapped, Boxed & Foamed	X	X	X	X	X	X
PM8	Microfoamed / Kraft Wrapped, Boxed, Foamed & Palletized			X	X	X	X
PM9	Hand Crate	X*	X*	X	X	X	X
PM10	Palletized - Microfilm Between Layers			X	X	X	X
PM11	Pallet Crate			X	X	X	X
PM12	Boxed, Foamed & Palletized			X		X	
PM16	Individually <u>Stretch Wrapped</u> (Front to Back and Side to Side), Boxed and Foamed.		X		X		X
PM17	Individually <u>Stretch Wrapped</u> (Front to Back and Side to Side), and Palletized				X		X
PM18	U-Channel Box	X*	X*	X	X	X	X
PM19	Oversized Hand Crate	X*	X*	X	X	X	X
PM20	Oversized Pallet Crate			X	X	X	X

Hazardous Material Packaging (each) See pricing chart in **Section A.1** of our current **Wholesale Pricing Catalog**. Charges are in addition to other Packaging Fees.

* = Restrictions may apply based on size and weight set forth by shipping company.

► For **PRICING** ► See **Section A.1** in our current **Wholesale Pricing Catalog**.



99.7% American Made

A.3.1
V18.1

Shipping/Handling

WalzCraft prides itself in manufacturing a high quality product within a delivery time frame that is second to none in our industry. WalzCraft will only ship product via "WalzCraft" approved shipping companies that have Mission Statements comparable to ours, thus the reason we do not use most third party logistics companies.

- **Order Shipping Options:**

- FedEx Ground
- UPS
- Spee•Dee (*some Midwestern states only*)
- Common Carrier
- Pick Up/Will Call.

- Freight charges for items shipped UPS, FedEx Ground or Spee•Dee will appear on your invoice.

- **All freight charges are F.O.B. La Crosse, WI.**

- **Note: Requests for product to be shipped next day air will be individually reviewed and undergo an approval process prior to being scheduled for shipment.**

- Shipping options for those orders to Canada, Guam, Puerto Rico, U.S. Virgin Islands, Alaska and Hawaii, will be reviewed at the time a quote or an order is being placed.

- If your terms are COD, Credit Card or Prepay, items shipped Common Carrier will be sent freight collect.

- **Common Carriers require payment by separate check** for freight/delivery charges regardless of WalzCraft invoice terms.

- Customers with Net 30 Day terms will be billed separately for items shipped common carrier.

- Any requested change made after an order has shipped will be subject to additional charges assessed by the carrier. Including, but not limited to:

- Delivery address changes.
- Request for lift gate.
- Notification of delivery.

- Size of the order, or items shipped, determine the shipping method. For instance, items larger than 165 girth inches cannot be properly packaged meeting UPS/FXG standards and will ship via common carrier.

- **To calculate girth inches . . .**

If door width is **less than** height ($width \times 2 + height + 18''$)
[457.2mm] for packaging = Girth Inches.

If door width is **greater than** height ($height \times 2 + width + 18''$)
[457.2mm] for packaging = Girth Inches.

WalzCraft will not be liable for products that are delayed due to the actions of any shipping or freight carrier.

Packaging 96" or Longer

Packages that are 96" [2438.4mm] in length or longer may incur substantial surcharges from some small package carriers and common carriers. When specifying a shipping company that employs this policy, you can avoid this surcharge by ordering product in lengths that when packaged do not exceed 95" [2413mm]. The most common type of product that normally exceeds 96" [2438.4mm] after being packaged is 8' moldings.

WalzCraft has created some alternatives to avoid these "Excessive Length" charges entirely:

- WalzCraft, at no additional charge, will cut an 8' molding to 93" and modify our packaging to a size just under the accepted carrier limit. If your order is anticipated to ship via small package carriers UPS or FedEx, WalzCraft strongly recommends considering the 93" option.
- WalzCraft is actively diverting "Excessive Length Shipments" to common carriers that are not instituting the charge at this time. If you have an "Excessive Length" package that can be diverted from UPS or FedEx Small Package to Common Carrier, there will sometimes be a cost savings.
- Please note that WalzCraft order forms now have a check box added to request that a molding(s) be cut to 93" to avoid "Excessive Length" charges.

Common Carrier Shipments

For larger orders, it is usually most economical to ship via Common Carrier. WalzCraft has negotiated rates with major carriers for delivery to different regions of the United States. These "WalzCraft Preferred Carriers" have been chosen because they have a favorable balance of Transit Time, Cost, On Time Delivery, and Low Damage Claims.

- If your order ships via Common Carrier and you do not have Net 30 Day terms with WalzCraft, shipping charges will be **Freight Prepaid**, meaning WalzCraft will apply shipping charges at the time the shipment leaves our facility. These charges are separate from the product charges from WalzCraft. Please contact our Customer Support Team for more information.

When Shipping via Common Carrier, there are additional services available that most carriers will provide, but they are only provided when requested, and when requested, there will be an additional fee. Some of the most common services are:

- **Call To Set Up Delivery**
 - Also known as "Delivery Notification", or just "Notification". If you need to have the delivering carrier call ahead to arrange delivery, please let WalzCraft know this and we will indicate this on the Delivery Receipt for your shipment.
- **COD Fees**
 - Common Carriers charge "Flat Fees" or sometimes "Percentage Fees" for COD Shipments. They do this to cover the costs incurred in collecting a check, processing it, and then reimbursing WalzCraft. Paying WalzCraft for your order with a Credit Card at the time you place your order is one way to avoid these COD fees.
- **Residential Delivery Fee**
 - There may be a fee to deliver to a residential area.

► For PRICING ► See Section A.1 in our current Wholesale Pricing Catalog.



Common Carrier Shipments...Continued

• **Lift Gate**

◦ A Lift Gate is a device installed on the back of some trucks or trailers that enables freight to be removed from the truck or trailer and gently lowered down to a hard surface (*see photos*). A Lift Gate is a great solution to unloading a delivery truck at a destination that does not have a loading dock. If Lift Gate Service is required, please let WalzCraft know this and we will indicate this on the Delivery Receipt for your shipment.



WalzCraft realizes that the services listed within this Common Carrier section are sometimes necessary, and we continually work with carriers to try to keep the associated fees reasonable and fair.

Pickup/Will Call

If you would like your order held for pickup at our facility, indicate this in the **Shipping Preference** area: **D Pick Up/Will Call** on your order form or tell our WalzCraft Customer Support Specialist when you place your order.

- Our staff will notify you when your order is ready for pickup. Pickup hours are 7:00 a.m. to 3:00 p.m., Central Standard Time, Monday through Friday. If you have not been contacted, **please confirm that your order is complete before scheduling a pickup.**
- **Orders are required to be picked up within 10 working days from the date of completion, or there will be a per day storage fee assessed. Please see Section A.1 of our current Wholesale Pricing Catalog for storage fees.**
- Pre-finished doors and drawer fronts held for pickup will be wrapped in Microfoam and / or Kraft Paper (PM2).

Shipping Arranged by Customer

Whenever a customer chooses to make “their own shipping arrangements” or to have their product picked up here at WalzCraft, the customer then must also take full ownership/responsibility with working with the selected trucking firm in the event of any shipping damage/losses.

Canadian Shipments

When WalzCraft ships orders to Canadian destinations, there will be freight charges, customs brokerage charges, and a charge for the applicable Canadian Taxes. If you prefer to use a specific Customs Broker, please let WalzCraft know the name, address, and phone number of your broker at the time you place your order. If you have no preference for a customs broker, WalzCraft will use a broker we have had previous experience with.

Shipping Damage/Damage Claims

- Always inspect packages for damage upon receipt. If there is no visible damage to the exterior of a package or skid, please note “Subject to Inspection for Internal Damage” on all Delivery Receipts.
 - If a package arrives damaged, we recommend accepting it and indicating damages on the Delivery Receipt. **No notation** generally results in denial of a damage claim by the carrier. Refusing delivery will cause delays in processing damage claims.
 - Notify our Customer Support Team of damaged product.
 - Damaged items are replaced immediately, at no charge.
 - Replacement items are shipped via the shipping method originally used. In cases where common carrier is not necessitated by size or quantity, replacement items will ship via small package carrier.
- In an effort to minimize business expenses, WalzCraft will process all shipping damage claims. Claims must be filed within 5 business days of delivery and include the following information:**
- Tracking or Delivery Receipt numbers.
 - Date product was received.
 - Name of the carrier delivering package.
 - Original packaging material must be kept for inspection.
 - Repack damaged item in original box, with original packaging material positioned as it was when the box was opened.
 - The Shipper will decide if the package should be returned to WalzCraft or held by the shipper, until claims are processed.

► **For PRICING** ► See Section A.1 in our current Wholesale Pricing Catalog.

Hazardous Material Packaging & Shipping/Handling

All of the finishing materials (ie: Stain, Glaze, SolidTone®, Clear Sealer, Clear Topcoat and Catalyst) sold by WalzCraft are considered “Hazardous Materials” and as such, have very specific shipping methods based on the container size being shipped.

- Container sizes of 1 gallon or smaller are eligible to ship per the “Limited Quantity” rules established by the Department of Transportation.

**Limited Quantity**

This symbol/label is affixed to the exterior of the box that the finishing material is shipped in. It signifies that the contents of the box comply with “Limited Quantity” shipping requirements.

- The only container size that WalzCraft offers that is greater than 1 gallon is the 5 gallon metal pail. This container size is only allowable to ship as a “HAZMAT” shipment which requires special paperwork, specific labels, HAZMAT approved cartons, and special carton markings.

Limited Quantity Containers

Finishing Material Container Options When Shipped as “Limited Quantity”	Freight Cost Consideration Small Package Carriers	Freight Cost Considerations Common Carrier (When Shipping with Other WalzCraft Products)
One-Quart Cans Packed in Limited Quantity Boxes	Standard Small Package Carrier Ground Rates No HAZMAT Fees	Standard Charge for Package Weight No HAZMAT Fees
One-Gallon Cans Packed in Limited Quantity Boxes		
Plastic Bottles Packed in Limited Quantity Boxes <ul style="list-style-type: none"> • Catalyst only • Each bottle holds up to 16 ounces of catalyst 		

HAZMAT Containers

Finishing Material Container Options When Shipped as “HAZMAT” (Container Sizes Larger Than 1 Gallon)	Freight Cost Consideration Small Package Carriers	Freight Cost Considerations Common Carrier (When Shipping with Other WalzCraft Products)
(1) - Five Gallon Steel Pail Packed in a Five Gallon HAZMAT Box (Clear Sealer and Clear Top Coat Only)	Standard Small Package Carrier Ground Rates PLUS HAZMAT Fees	Standard Charge for Package Weight PLUS HAZMAT Fees

Limited Quantity and HAZMAT

WalzCraft will ship finishing materials (Hazardous Materials) as “Limited Quantity” or “HAZMAT” only to the contiguous United States and only via ground carriers.

- Due to California state law, WalzCraft does not ship finishing material (ie: cans of Stain, Glaze, SolidTone®, Clear Sealer, Clear Topcoat or Catalyst) to **California-CA**.
- Walzcraft does not ship finishing material to **Alaska-AK** or **Hawaii-HI**, as they are not part of the contiguous United States and would need to be shipped via air (airplane). WalzCraft only ships these materials via ground carriers.
- WalzCraft does not ship finishing material to international destinations or to destinations that require air or sea transport.
- For all these cases, WalzCraft recommends that you seek local sources for finishing materials.

Limited Quantity**Guidelines for Packaging “Limited Quantity” Shipments:**

- In an effort to control costs, WalzCraft will package finishing material in as few boxes as possible.
- Stain, Glaze, SolidTone®, Clear Sealer and Clear Topcoat are available by the ½ pint, pint, quart or gallon, are always packaged in a quart or gallon can, and the cans can be placed in the same box, depending on the quantity of quart and/or gallon cans needed to fill the order.
 - If ordering a pint, a quart can is filled half full.
 - If ordering a ½ pint, a quart can is filled ¼ full.
 - The smaller quantities are shipped in quart cans because of “Limited Quantity” labeling requirements/sizes. Quart cans are the smallest size can we can provide while still complying with these requirements.
- Catalyst is available by the ounce, and is packaged in plastic bottles that can hold up to 16 ounces.

► For PRICING ► See Section A.1 in our current Wholesale Pricing Catalog.

HAZMAT

Guidelines for Packaging “HAZMAT” Shipments:

- In an effort to control costs, WalzCraft will package finishing material in as few boxes as possible.
- If any part of the finish material order needs to ship as HAZMAT, the entire finish material order will ship as HAZMAT. The shipment will not be broken into separate Limited Quantity and HAZMAT shipments.
- Clear Sealer and Clear Topcoat are available in 5 gallon metal pails, packed in a corrugated box.
- Catalyst is available in 5 gallon plastic pails, packed in a corrugated box.
- HAZMAT box charges will be reflected on your WalzCraft invoice.
- A handling fee to transport HAZMAT shipments via ground carrier is assessed by each individual carrier and at times can be rather costly. This charge is in addition to normal packaging and freight charges. Should this shipping charge become prohibitive, we suggest that you seek local sources for your finishing material.
- When shipping HAZMAT shipments, all carriers will require a signature from someone at least 18 years of age at time of delivery.
- See **Section A.1** of our current Wholesale Pricing Catalog for “HAZMAT” box pricing.

Return/Recycle Drawer Box H-Clips

- H-Clips are used when stacking drawer boxes on top of each other during shipping. If you accumulate more than 1000 of these from WalzCraft you may return them for reuse in our Recycling Initiatives Program.
- Place H-Clips in used WalzCraft boxes, notify us and we will issue a call tag to have them picked up.

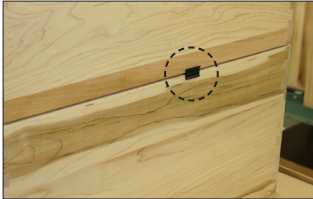

Return/Recycle Pallets

If you have an accumulation of 48" [1219.2mm] x 40" [1016.0mm] **interlocking fiber/chipboard pallets** from WalzCraft deliveries, you may return them for reuse in our Recycling Initiatives Program. You will incur no landfill charges and help us control future costs.

- **Pallets must be bundled in stacks no less than 50 pieces, be kept indoors and dry.**
- Please call our Purchasing Department to notify us of your need for a pick up. We will arrange a common carrier to pick up the pallets at your facility.

Return/Recycle Packaging Corners

- Die Cut Foam Corners are used for packaging product. If you accumulate more than 100 of these from WalzCraft you may return them for reuse in our Recycling Initiatives Program.
- Place corners in used WalzCraft boxes, notify us and we will issue a call tag to have them picked up.



Recycle Foam Packaging

- Instapak® foam used in our packaging can be returned to various Sealed Air sites located across the United States.
- For a complete list of the sites available, please go to the Sealed Air Instapak® Foam Return Program website: www.sealedair.com/recycle



► **For PRICING** ► See **Section A.1** in our current Wholesale Pricing Catalog.

Door & Drawer Front Parts/Grain Direction

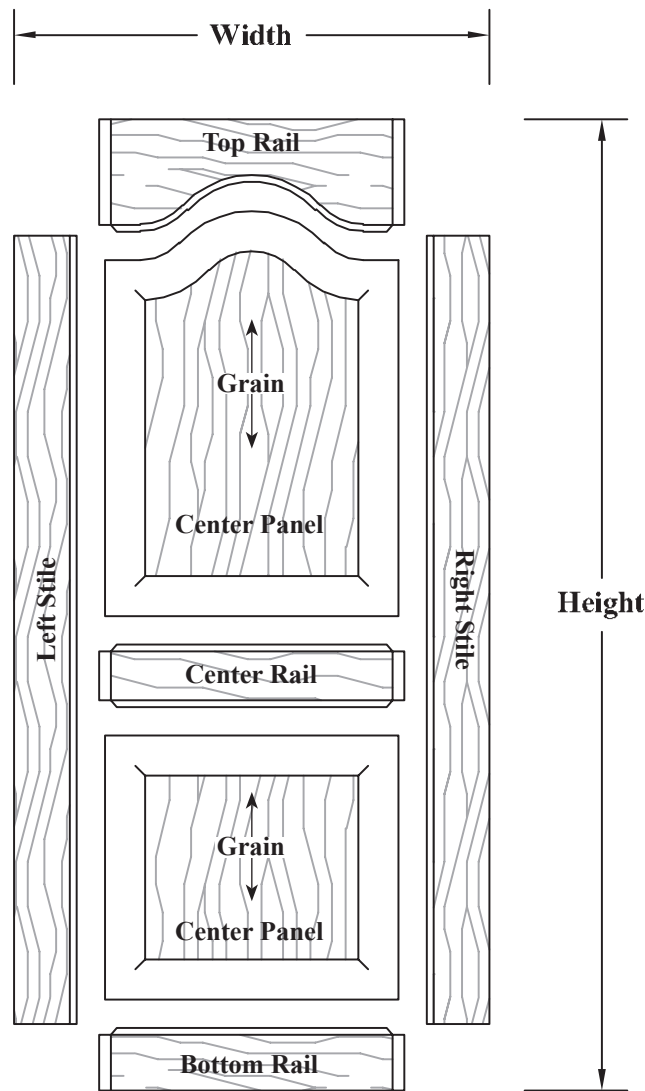

Exploded View of Style 2010

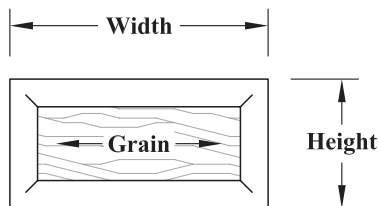

Typical Slab or RP Drawer Front

Grain Direction (←→)

- Arrows throughout the catalog indicate standard grain direction.
- Grain direction may be specified at *no* additional cost.
- Standard grain direction on door styles shown without an arrow, would be vertical.

► For PRICING ► See Section A.1 in our current Wholesale Pricing Catalog.

3/4" - "Traditional" Door Construction (Typical Construction)

- **3/4" Thick "Traditional" doors & drawer fronts** will have stiles and rails that are 2 1/4" [57mm] wide and 3/4" [19.1mm] thick.
 - The 3/4" [19.1mm] thickness is measured at the stile / rail's thickest point.
 - The overall width of the stile / rail includes the width of the Outside Edge Profile, the width of the Stile & Rail Profile and the flat space in between the two. It does not include applied moldings.
- **Outside Edge Profiles** for 3/4" [19.1mm] thick "Traditional" door & drawer front construction can be found in *Sections E.15* and *E.16*.
- **Stile & Rail Profiles** for 3/4" [19.1mm] thick "Traditional" door & drawer front construction can be found in *Sections E.1, E.2, E.4, E.5* and *E.6*.
- **Center Panel Profiles** for 3/4" [19.1mm] thick "Traditional" door & drawer front construction are found in *Sections E.12* and *E.13*.
 - 3/4" [19.1mm] thick solid wood or raw MDF raised center panels are flush to the stiles & rails on the face and back side of the door (see illustration below). See *Section E.12*.
 - The **RVSCP-PR324 (Reversed Solid Center Panel)** is recessed .5mm from the stiles & rails on the back side of the door (see illustration below). This also applies to 3/4" [19.1mm] thick "Mitered" doors or drawer fronts. See *Section E.13*.
 - Flat panel doors and drawer fronts are constructed with a 1/4" [6.4mm] thick veneered MDF core panel or a raw MDF panel. There is a minimum 1 1/2" [38.1mm] of visible panel height required for flat panel doors or drawer fronts. See *Section B.3, B.4, B.6*.

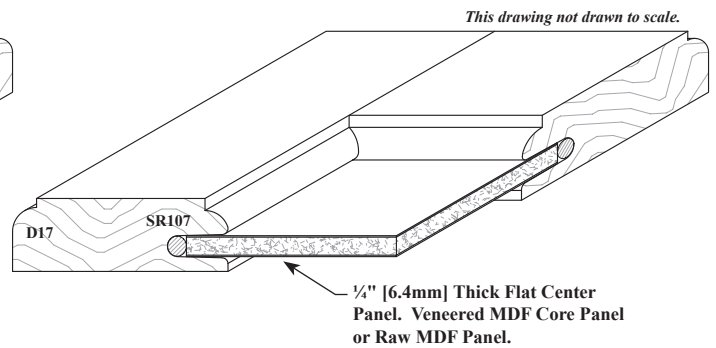
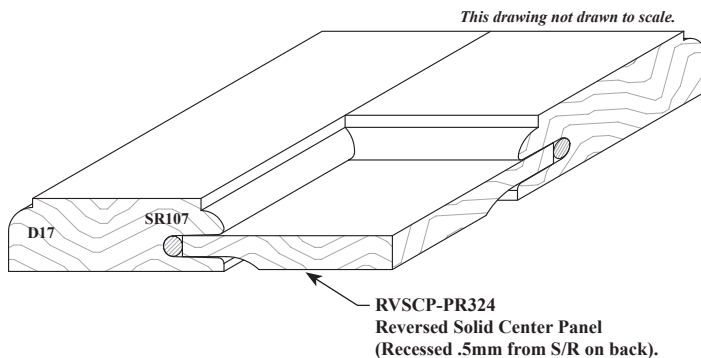
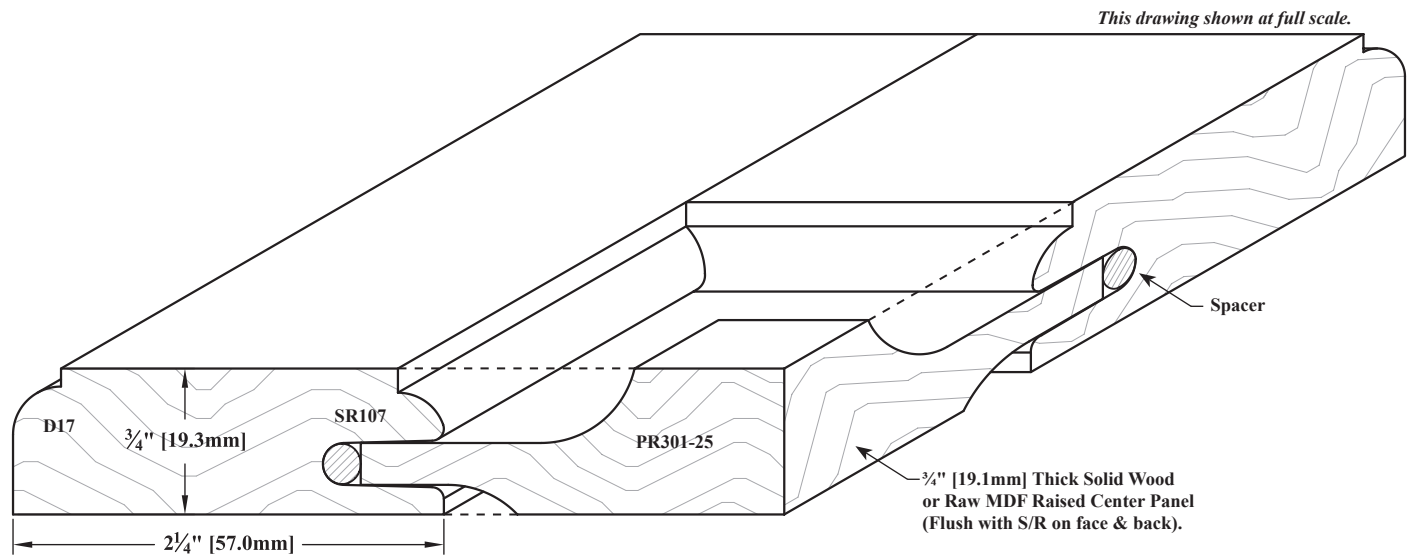

► For PRICING ► See Section A.1 in our current Wholesale Pricing Catalog.

1" - "Traditional" Door Construction (Typical Construction)

- **1" Thick "Traditional" doors & drawer fronts** will have stiles and rails that are 2¼" [57.2mm] wide and 1" [25.4mm] thick.
 - The 1" [25.4mm] thickness is measured at the stile/rail's thickest point.
 - The overall width of the stile/rail includes the width of the Outside Edge Profile, the width of the Stile & Rail Profile and the flat space in between the two. It does not include applied moldings.
- **Outside Edge Profile** dimensions do not change from the ¾" [19.1mm] thick "Traditional" door construction and can be found in **Sections E.15 and E.16**.
 - Additional thickness for 1" [25.4mm] thick "Traditional" construction is added to the back side of the stile/rail (*see illustration below*).
- **Stile & Rail Profile** dimensions do not change from the ¾" [19.1mm] thick "Traditional" door construction and can be found in **Sections E.1, E.2, E.4, E.5 and E.6**.
 - Additional thickness for 1" [25.4mm] thick "Traditional" construction is added to the back side of the stile/rail (*see illustration below*).
- **Center Panel Profiles** for 1" [25.4mm] thick "Traditional" door & drawer front construction are found in **Sections E.12 and E.13**.
 - ⅝" [15.9mm] thick solid wood or raw MDF raised center panels are flush to the stiles & rails on the face and recessed ⅜" [9.5mm] from the back (*see illustration below*). See **Section E.12**.
 - The **RVSCP-PR324 (Reversed Solid Center Panel)** is recessed .5mm from the stiles & rails on the back side of the door (*see illustration below*). This also applies to 1" [25.4mm] thick "Mitered" doors or drawer fronts. See **Section E.13**.
 - Flat panel doors and drawer fronts are constructed with a ¼" [6.4mm] thick veneered MDF core panel or raw MDF panel. There is a minimum 1½" [38.1mm] of visible panel height required for flat panel doors or drawer fronts. See **Sections B.3, B.4, B.6**.

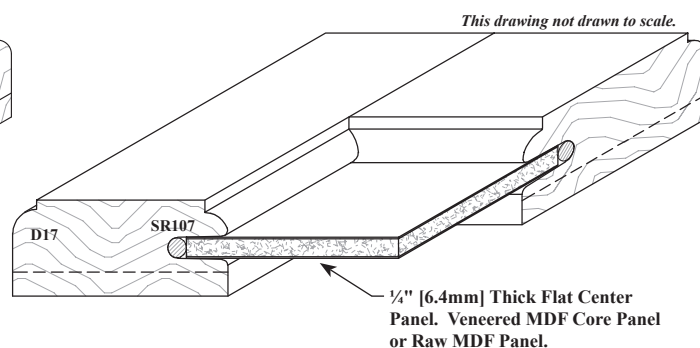
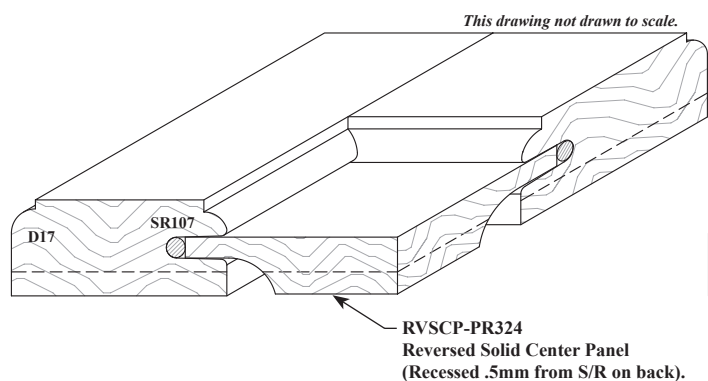
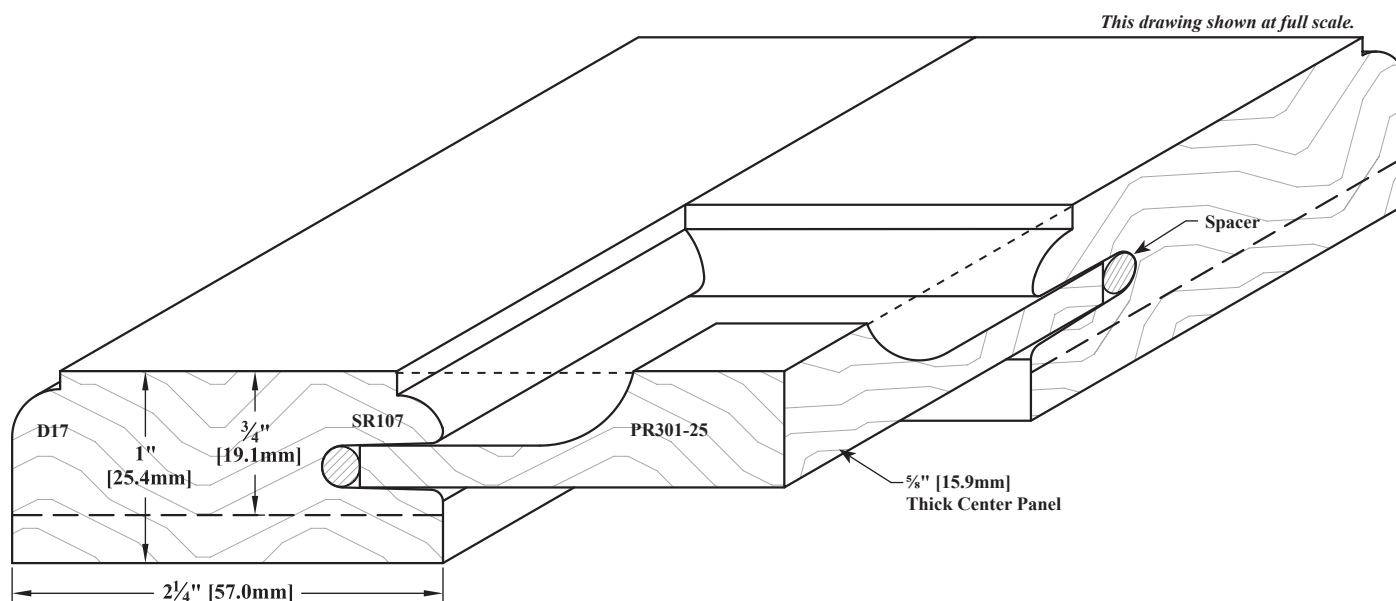

► For PRICING ► See Section A.1 in our current Wholesale Pricing Catalog.

1" - "Old World" Door Construction (Typical Construction)

- **1" [25.4mm] Thick "Old World" door & drawer fronts** will have stiles and rails that are 3" [76.2mm] wide and 1" [25.4mm] thick.
 - The 1" [25.4mm] thickness is measured at the stile/rail's thickest point.
 - The overall width of the stile/rail includes the width of the Outside Edge Profile, the width of the Stile & Rail Profile and the flat space in between the two. It does not include applied moldings.
- **Outside Edge Profile** dimensions do not change from the ¾" [19.1mm] thick "Traditional" door construction and can be found in *Sections E.15 and E.16*.
 - The same Outside Edge profiles are used for all door construction methods (excludes **MP700** and **MP900** series of profiles).
- **"Old World" door construction** has modified dimensioning for Stile & Rail and Center Panel profiles. They are larger/deeper than the "Traditional" profiles.
 - Please note, these profiles are not compatible with ¾" [19.1mm] and 1" [25.4mm] thick "Traditional" door construction.
- **Stile & Rail Profiles** for 1" [25.4mm] thick "Old World" door & drawer front construction can be found in *Sections E.3, E.4, E.5 and E.11*.
 - Additional thickness for 1½" [28.6mm] and 1¼" [31.8mm] thick "Traditional" construction is added to the back side of the stile/rail.
- **Center Panel Profiles** for 1" [25.4mm] thick "Old World" door & drawer front construction can be found in *Section E.13 and E.14*.
 - ¾" [19.1mm] thick solid wood or raw MDF raised center panels are flush to the stiles & rails on the face and recessed ¼" [6.4mm] from the back side of the door (see illustration below). See *Section E.13*.
 - The **RVSCP-PR324 (Reversed Solid Center Panel)** is recessed .5mm from the stiles & rails on the back side of the door (see illustration below). See *Section E.13*.
 - Flat panel doors and drawer fronts are constructed with a ¼" [6.4mm] thick veneered MDF core panel or raw MDF panel. There is a minimum 1½" [38.1mm] of visible panel height required for flat panel doors or drawer fronts. See *Sections B.3, B.4, B.6*.
- **"Old World" doors** are also available in 1½" and 1¼" thicknesses. Please see the **Size / Dimension Notes** in *Section E.3*.

This drawing shown at full scale.

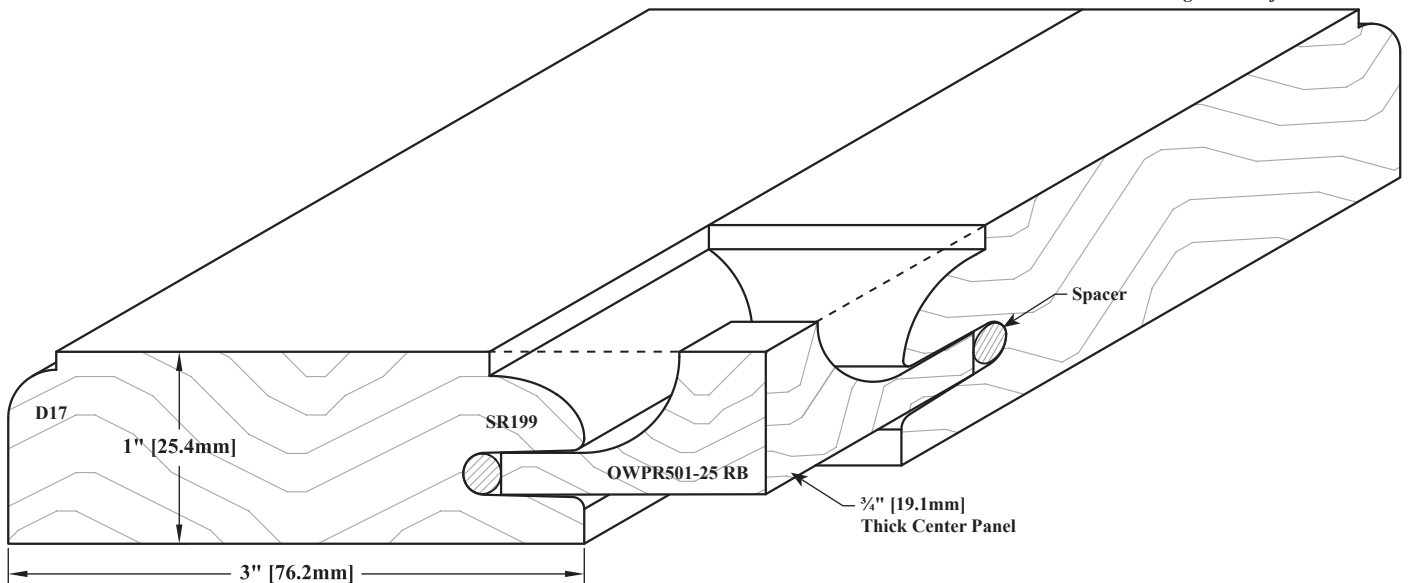

This drawing not drawn to scale.

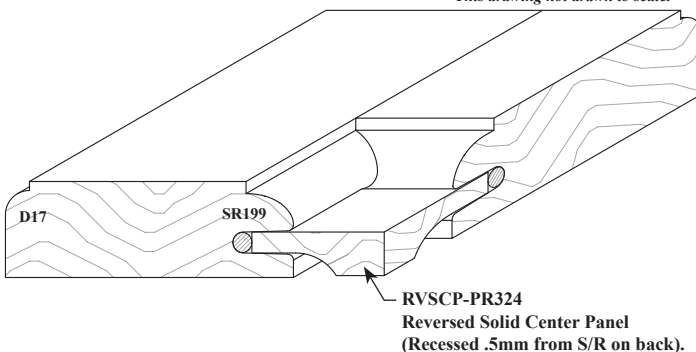

This drawing not drawn to scale.

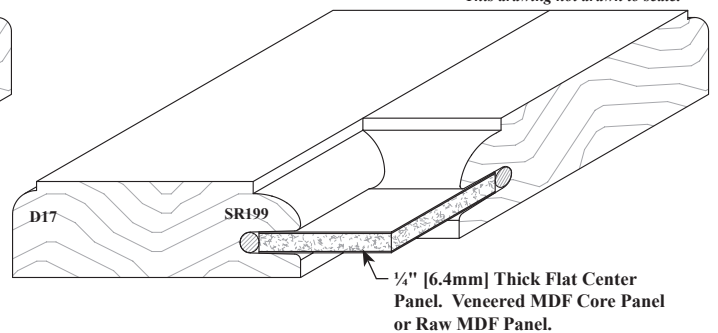

► For PRICING ► See Section A.1 in our current Wholesale Pricing Catalog.

Center Rail Placement**Standard Center Rail Placement**

- Certain double panel doors, such as Styles 1000 and 8000, are shown as 60/40 split and 50/50 split, which refers to the center rail placement.
 - In the case of a 60/40 split, the upper panel is the larger panel and makes up 60% of the total visual opening space; the lower panel makes up 40%.
 - In the case of a 50/50 split, the total visual opening space is divided equally.

Custom Center Rail Placement

- Custom placement of a center rail is available and refers to the distance from the top of the top rail, to the top of the center rail for most door styles (see individual product notes for exceptions on where to measure for CR placement).

Please indicate this placement in the *Special Instructions* area on the order form.

Panel Matching

- Our main focus is towards color and grain matching on the face of the panel.
- Panels are not matched with any regard to the direction of the growth rings in the lumber. (Most panels are composed of wood from several different boards, so the need to control growth ring orientation is not as critical.)

Flat Panel Door “Look”

To achieve the best possible color and grain match, with a Flat Panel Door “Look”, we recommend ordering a door with a **reversed solid center panel** (*ie: RVSCP-PR324*) *see E.13*. The entire door would be solid wood, avoiding the possibility of mismatch between the veneered center panel & solid wood frame.

Door Styles Using Corner Blocks

- Corner blocks are used to create the shape for the top and / or bottom rails for the following door Style #'s: **1020, 1060, 1070, 1080, 1090, 2121L, 2121R, 2100L, 2100R, 2416, 2417, 2418, 2419, 2829, 2834, 3100L, 3100R, 3131L, 3131R, 3139, 4060, 4070, 4080, 4090, 4050, 4055 and 4010.**
- In all cases the grain direction of the corner block shall be **horizontal**.

Pinless Door Construction

The majority of our doors are assembled using the WalzCraft Quality Standard of **pinless** door construction. Doors are kept in a clamp, under pressure, until the glue has set; therefore, no pins are required. This construction method provides a stronger, high-quality product.

- There are a few exceptions such as where some doors may be pneumatically pinned to hold a corner block in place. In this case, the pins are driven below the surface of the wood on the back of the door. The small hole that is left is **not** filled with putty.
- Some applied moldings may also be attached with small headless pins.

Products For Exterior Use

We do not recommend use of our products in an exterior environment. Tolerances are engineered for interior use only. There will be no warranty when any WalzCraft product is installed outdoors.

“Ready to Assemble” (RTA) Products

Shipping product RTA is an option, should an item be too large to ship via ground carrier, and you prefer not to ship them via common carrier. **Shipping RTA is not an option for prefinished products, with the exception of face frames.** RTA products require additional manufacturing operations prior to shipping:

- Doors and Frame Only parts are dry fitted and sanded to the proper thicknesses. An outside edge is applied before finish sanding.
- Face Frame parts are bored for pocket screws and screwed together without glue, before finish sanding.
- Each joint on every product piece is labeled before disassembly, to ensure they are put back together correctly.
- An assembly drawing is provided with all RTA products.
- Screws are provided with RTA face frames.
- Please see *Section A.1* of our current **Wholesale Pricing Catalog** for RTA charges.

Pressure Sensitive Veneer

- Also referred to as Peel and Stick Veneer or PSA Veneer.
- For flawless results, we recommend that you use a smoothing tool versus a J-roller when applying this material.
 - A J-roller **will not apply** enough pressure to achieve an intimate bond.
- **Veneer Smoothing Tools** are available for purchase. Refer to *Section U.2* for additional information.

“Green” & Environmental Products

- Committed to informing our customers of the “Green” and Environmentally Friendly choices & opportunities available.
- By educating each other and working together, we can provide new ideas and products that meet a common goal of producing and purchasing more wisely.
- To learn more about “Green” products offered by WalzCraft, visit our website at **WalzCraft.com**.

Fire Rating

- WalzCraft products are **not** officially fire rated.

Technical Info & Product Specs Disclaimer

- The technical information presented in this book with regard to dimensions and drawings is not binding. **As of the printing of this catalog, all technical information is believed to be accurate. For the most current technical information, please visit our website.**
- WalzCraft reserves the right to improve designs, and to change specifications without notice.
- This publication supersedes all prior technical, policy, customer support and pricing data.

► **For PRICING** ► See *Section A.1* in our current Wholesale Pricing Catalog.

Signature Series Key

Our “Signature Series” designs are featured in various WalzCraft marketing campaigns, allowing you to easily tailor product to your customer’s specifications. Please visit our website at www.WalzCraft.com / SignatureSeries for more information about our “Signature Series” doors and drawer fronts and how to place an order using the “Advanced” Version of our E-Z Order Forms.

Mortise & Tenon (263)

View All Selections

Sort By: Signature Series #

Display: All

Per Page: 12

1 2 3 4 5 ... 50 Next

S100 Unity Compare

S101

S102

S103

S104

S105

S106

S107

S108

S109

S110

S111

S112

S113

S116

S117

S118

S102 Marquee Compare

S133 Marquee



View Profile

Drawer Front Specifications
as shown

Drawer Front Style: Style 10M*

Stile & Rail Profile: MP760-38 (MP760R)

Panel Profile: PR305-19 (PR208)

Grain Direction: Horizontal

Wood Species: Maple - Hard

Wood Grade: Select / Premium Grade

Thickness: 3/4"

Stain/RTF Color: Fruitwood

Finish Type: Spray No Wipe

Cabinet Door Specifications
as shown

Door Style: Style 10M

Stile & Rail Profile: MP760-76 (MP760)

Panel Profile: PR305-19 (PR208)

Grain Direction: Vertical

Wood Species: Maple - Hard

Wood Grade: Select / Premium Grade

Thickness: 3/4"

Stain/RTF Color: Fruitwood

Finish Type: Spray No Wipe

Signature Series Drawer Front Designs Shown with the Width Reduced on the Top & Bottom Rails

WalzCraft depicts some Signature Series Door/Drawer Front Combinations with a “reduced” top & bottom rail on the drawer front. These can either be Traditional, French Mitered or Mitered Profiles. (S191) *Madison* and (S133) *Marquee* are two examples (please note that when reducing rail widths on a “Mitered” drawer front, the stiles will also need to be reduced proportionately). The reduced top & bottom rail is used on these drawer fronts to create a taller center panel resulting in a better proportioned appearance for that drawer front, and will also allow more room for larger hardware.

The fact that WalzCraft only depicts top & bottom rails with reduced sizes on the drawer front is not meant to indicate that a drawer front can only be ordered that way, but rather indicates that it is just one possible way to deal with drawer fronts that are not very tall. Using a reduced part size on the top & bottom rail is also typical for drawers that are located above doors on kitchen base cabinets. The space for the drawer front will usually be in the vicinity of 6" [152.4mm] in height, so reduced profiles are often used for these drawer fronts. *It should be noted, however, that the appearance of the completed kitchen often looks better when the drawer fronts that are below the top drawer use the same size rails as the doors adjacent to them.* Please carefully consider the design of the kitchen and choose the appropriate profiles for each instance.

S133 - Marquee “Advanced” E-Z Door Order Form

Wood Species * Maple - Hard

Wood Grade * Select / Premium

Thickness * 3/4"

Grain Direction Standard (as indicated in 17.2 Product Spec. Catalog)
 Vertical Horizontal

Profile Info
 Stile & Rail or Miter Profile MP760-76
 Panel Profile PR305-19
 Outside Edge Profile N/A

Signature Series Number and Name
 S#/Name S133 Marquee

Standard Profiles & Options Modified Profiles & Options
 Match Standard Options & Customer Specific Features shown on Website

S133 - Marquee “Advanced” E-Z Drawer Front Order Form

Wood Species * Maple - Hard

Wood Grade * Select / Premium

Thickness * 3/4"

Grain Direction Standard (as indicated in 17.2 Product Spec. Catalog)
 Vertical Horizontal

Profile Info
 Stile & Rail or Miter Profile MP760-38
 Panel Profile PR305-19
 Outside Edge Profile N/A

Signature Series Number and Name
 S#/Name S133 Marquee

Standard Profiles & Options Modified Profiles & Options
 Match Standard Options & Customer Specific Features shown on Website

► For PRICING ► See Section A.1 in our current Wholesale Pricing Catalog.

Moisture Content of Wood

The Effects of Moisture Changes On Wood

Some of the following information was taken from information compiled by
Dr. Gene Wengert, Professor and Extension Specialist in Wood Processing
Department of Forestry, University of Wisconsin, Madison.

Moisture and Relative Humidity (RH)

Wood is a hygroscopic material, meaning that it is continually trying to achieve an equilibrium condition with its environment. As the relative humidity (RH) changes, so does the moisture content of the wood. The following table shows the relationship between the relative humidity of the air and the moisture content of wood.

Relative Humidity of the Air	Moisture Content of Wood
1-7%	2%
8-13%	3%
14-19%	4%
20-25%	5%
26-31%	6%
32-38%	7%
39-45%	8%
46-51%	9%
52-57%	10%
58-63%	11%
64-69%	12%
70-75%	13%
76-81%	14%
82-87%	15%
88-93%	16%
94-100%	17%

Please note that temperature is not an important factor; it's just the relative humidity. Here at WalzCraft we keep our relative humidity in the 32-38% range during the winter months. This means moisture content in the wood leaving here is approximately 7%. So, as an example, let's say we ship an order of unfinished Hard Maple doors to a very humid climate such as Florida. Relative humidity in the range of 58-64% is not uncommon in southern states. Remember that wood is a hygroscopic material and will attempt to take on moisture to arrive at an equilibrium with its new environment. In this case the doors will increase in moisture content from 7% to 11%. Four percentage points doesn't seem like much, *but it is in fact a 57% increase in moisture* for these particular doors.

Moisture Effects on Wood Expansion and Contraction

To better understand the effects of moisture content, we must realize that the properties of wood change dramatically with changes in moisture content. The most noteworthy change is shrinking and swelling, especially across the grain of the wood. As you can see from the chart below, a Hard Maple door with a center panel 18" [457.2mm] wide will expand more than ¼" [6.4mm] *when the moisture content increases by 4%*. If proper allowances are not made within the door, this much panel expansion will act like a hydraulic jack and force the door apart.

Panel Size	2% Change in Moisture Content	4% Change in Moisture Content	6% Change in Moisture Content	8% Change in Moisture Content
152.4mm (6") Wide Center Panel	1.07mm (1/16")	2.13mm (3/32")	3.20mm (1/8")	4.27mm (3/16")
304.8mm (12") Wide Center Panel	2.13mm (3/32")	4.27mm (3/16")	6.40mm (1/4")	7.90mm (5/16")
457.2mm (18") Wide Center Panel	3.20mm (1/8")	6.40mm (1/4")	9.60mm (3/8")	12.80mm (1/2")
609.6mm (24") Wide Center Panel	4.27mm (3/16")	8.53mm (11/32")	12.80mm (1/2")	16.00mm (5/8")
762.0mm (30") Wide Center Panel	5.33mm (7/32")	10.67mm (7/16")	16.00mm (5/8")	20.60mm (13/16")
914.4mm (36") Wide Center Panel	6.40mm (1/4")	12.80mm (1/2")	19.20mm (3/4")	25.40mm (1")

► For PRICING ► See Section A.1 in our current Wholesale Pricing Catalog.

1-800-237-1326 *WalzCraft*® www.WalzCraft.com

Standard & Non-Standard Part Sizes

Standard Stile & Rail Widths

- Stile and rail widths are determined by measuring across the back of the stiles and rails only.
- **Traditional & Adventure Series (ASTP)** Doors & Drawer Fronts
 - ¾" [19.1mm] & 1" [25.4mm] thick = 2¼" [57.2mm] wide.
- **Old World & Adventure Series (ASTP)** Doors & Drawer Fronts
 - 1" [25.4mm], 1½" [28.6mm] and 1¾" [31.8mm] thick = 3" [76.2mm] wide.
- **Mitered / French Mitered / Adventure Series (ASMP)** Doors & DFs
 - ¾" [19.1mm] & 1" [25.4mm] thick = 1½" [38.1mm] wide, 2¼" [57.2mm] wide and 3" [76.2mm] wide.
 - Some center rails and center stiles pictured in the catalog for Mitered and French Mitered doors have unique sizes and are not able to be modified in width.
- **MDF / RTF** Doors & Drawer Fronts
 - ¾" [19.1mm] & 1" [25.4mm] thick = 2¼" [57.2mm] wide.
- **Passageway Doors**
 - 1¼" [31.8mm] to 2½" [63.5mm] thick = 9" [228.6mm] wide bottom rail, 8" [203.2mm] wide lockset rail with remaining stiles & rails at 4½" [114.3mm] wide.
- Reducing standard part sizes on Traditional, Old World, Mitered, French Mitered, MDF/RTF and Passageway doors gives you the ability to order doors smaller than the printed minimum size.
- Modifying the widths of any outside stiles & rails or center stiles & rails to anything other than the dimensions listed in the charts below will result in the addition of a Non-Standard part size charge. This charge will be for *each* stile and rail that deviates from the aforementioned widths. Please see **Section A.1** of our current **Wholesale Pricing Catalog** for charges.
- WalzCraft *will not be responsible* for determining non-standard part sizes. You must specify the sizes required for your construction needs.

Traditional, Old World, Adventure Series (ASTP) MDF/RTF & Passageway Doors
Stile/Rail Widths Not Subject to Non-Standard Parts Size Charge

1½" 38mm	1¾" 44mm	2" 51mm	2¼" 57mm	2½" 64mm	2¾" 70mm	3" 76mm
3¼" 83mm	3½" 89mm	3¾" 95mm	4" 102mm	4¼" 108mm	4½" 114mm	4¾" 121mm
5" 127mm	5¼" 133mm	5½" 140mm	5¾" 146mm	6" 152mm	6¼" 159mm	6½" 165mm
6¾" 171mm	7" 178mm	7¼" 184mm	7½" 191mm	7¾" 197mm	8" 203mm	8¼" 210mm
8½" 216mm	8¾" 222mm	9" 229mm	9¼" 235mm	9½" 241mm	9¾" 248mm	10" 254mm

Mitered Doors (MP600 / MP6000 Series Only) French Miter & Adventure Series (ASMP) Doors
Stile/Rail Widths Not Subject to Non-Standard Parts Size Charge

1½" 38mm	1¾" 44mm	2" 51mm	2¼" 57mm	2½" 64mm	2¾" 70mm	3" 76mm
-------------	-------------	------------	-------------	-------------	-------------	------------

- Any non-standard miter profile widths that are published in the WalzCraft Specification Catalog are exempt from Non-Standard part size charges.

Minimum Size Doors

Traditional Door & Drawer Front Construction

Minimum sizes (W & H) for 5-piece mortise & tenon doors or drawer fronts are listed under each Style #, beneath the Price Class. These minimum sizes are determined using the following component part sizes and dimensions:

- 2¼" [57.2mm] wide stiles & rails.
- 1¼" [31.8mm] center panel profile reveal.
 - The center panel profile reveal size is denoted on each line drawing; see **Profiles** chapter of this catalog.
- 1" [25.4mm] of flat surface is maintained on the face of a raised solid or MDF center panel or the back side of the **RVSCP-PR324 (Reversed Solid Center Panel)** profile.
- 1½" [38.1mm] of flat surface is maintained on the face of a ¼" [6.4mm] veneered center panel.

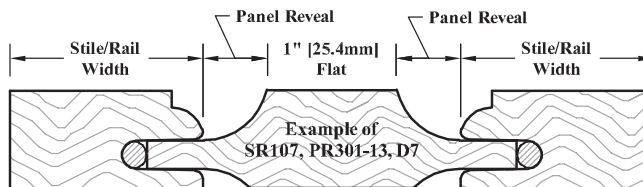

- If a Traditional door is ordered smaller than the minimum size and changing the panel profile or reducing the stiles and rails will not allow for 5 piece mortise & tenon construction, the door could be made as a slab or raised panel drawer front. The outside edge may match that of the edge used on your doors; the wood grain may also run parallel with the grain in the center panel of the doors.

Reducing Center Panel Profile Reveals

The following information explains how to order 5 piece doors and drawer fronts below their minimum size allowance.

- Reduce center panel profile reveals
- Reduce stile and/or rail part sizes
- Any combination of: a) or b) above

If the Center Panel Profile Reveal is . . .

- 2" [50.8mm] wide, add 1½" [38.1mm] to the minimum door size.
- 1¼" [31.8mm] wide, use minimum door size listed.
- 1" [25.4mm] wide, deduct ½" [12.7mm] from the minimum size.
- ¾" [19.1mm] wide, deduct 1" [25.4mm] from the minimum size.
- ½" [12.7mm] wide or less: *See guidelines for Minimum Rail or Center Stile/Rail Part Sizes*

Left/Right Door Styles: 2100, 2121, 3100 and 3131

Stile & rail and panel profile reveals *cannot* be reduced to allow ordering below the minimum door sizes listed, due to the radius and corner block construction on these doors.

► For PRICING ► See Section A.1 in our current Wholesale Pricing Catalog.



Minimum Stile / Rail Part Sizes

- Stile and rail widths and lengths are determined by measuring across the back of the stiles and rails only.
- **2 1/8"** [54.0mm]: Minimum visual length for a solid wood top/bottom rail and center stile/rail.
 - We are unable to use the **"reducing guidelines"** noted to reduce door or drawer front sizes below their minimum size limitations when the center panel profile reveal is equal to or less than 1/16" [14.3mm] wide, such as the **RVSCP-PR324** and **PR309-13**; this generally results in the center stile/rail or top and bottom rails being shorter than the **2 1/8"** [54.0mm] minimum length allowance.
- **1 1/4"** [31.8mm]: Minimum width, at the narrowest point, for any top/bottom rail with or without a "GRF" cut.
- **1 1/2"** [38.1mm]: Minimum width, at the narrowest point, for any outside stile, center stile or center rail with or without a "GRF" cut.
- **1 3/4"** [44.5mm]: Minimum width, at the narrowest point, for any stile or rail with hinge boring, without a "GRF" cut (**2"** [50.8mm] minimum width when using 7mm or 8mm Cup Boring Distance). See **Section F.1**.
- **2"** [50.8mm]: Minimum width, at the narrowest point, for any outside stile or rail with hinge boring & a "GRF" cut (**2 1/4"** [57.2mm] minimum width when using 6mm, 7mm or 8mm Cup Boring Distance). See **Section F.1**.
- **3/16"** [4.8mm]: Minimum distance for the flat surface between the stile and rail profile and the outside edge profile; this factor may also affect the minimum size required for hinge boring.
- **1"** [25.4mm]: Minimum distance for the flat surface between moldings for any center stile or center rail with shelf applied molding.
- Some outside edges and stile & rail profiles may not be compatible if you reduce stile & rail parts to their minimum size.
 - Please reference our website for stile/rail and outside edge profile dimension charts.
 - See **"Standard & Non-Standard Part Sizes"** on the previous page to determine sizes subject to up-charges.

Veneered/Laminated Product Thickness Tolerances

- Products that have been veneered or laminated will carry a finished thickness tolerance that WalzCraft considers to be acceptable.
- Variances in thickness will occur when stacking multiple layers of material (ie: Core thickness + veneer thicknesses + glue lines, and when applicable, applied molding).
- These products include, but are not limited to:
 - Style 60 doors and drawer fronts (**Sections B.10, B.11**).
 - Custom Pressed products (**Section K.4**).
- See individual products for specific thickness tolerances allowed.
- Please allow for these tolerances in thickness when planning your project.

Oversized Doors

- Doors **more than 14 square feet** are considered oversized and are subject to upcharges. Please see **Section A.1** of the **Wholesale Pricing Catalog** for charges.
- **Oversize upcharges do not apply to mullion, MDF/RTF or Passageway doors.**

Oversized Panels

- All doors with solid wood **center panels that measure more than 32" [812.8mm] across the grain** and solid wood **slab doors that measure more than 32" [812.8mm] across the grain** will be considered oversized and are subject to the Oversized Panel upcharge.
 - Adding a center stile or center rail to divide the single oversized panel into two smaller panels that measure less than 32" [812.8mm] across the grain will eliminate the Oversized Panel upcharge.
- Please see **Section A.1** of our current **Wholesale Pricing Catalog** for Oversize Panel upcharges.
- Please see **Section A.8 - Warranties** for more information on Glued Up Panel expansion/contraction, warping, bowing and twisting.

Assembled Products Over 50"W x 50"H

- When a product such as a custom wainscot panel exceeds 50" [1270.0mm] in width **and** 50" [1270.0mm] in height combined, it can no longer fit through our wide belt sanders. A wide belt sander is what normally sands our products to their finished thickness after assembly. When a product can no longer be run through our wide belt sanders, the method of construction we use needs to be altered. In this case the stiles and rails are produced at their finished thickness through our molders, and then the product is assembled. This then necessitates sanding of the joints where the stiles and rails meet to be done by hand.
- There will be a per joint charge added to the total cost of each product that exceeds 50" [1270.0mm] in width **and** 50" [1270.0mm] in height. See **Section A.1** of our current **Wholesale Pricing Catalog** for charges.

Size (W x H) Tolerances

- WalzCraft warrants the outside dimensions of all products to be within a size tolerance of +/- 1 mm.
- While WalzCraft still maintains a size tolerance of +/- 1 mm, it is normal to observe greater variations in size for products with Applied Molding Outside Edges. The finished size of AMOSE doors are the 'sum' of what the door core, 2 moldings, and two glue lines add up to, and will inherently have more variations in size than products that are CNC routed to their finished size. This additional variation can potentially affect project constraints such as the gap for Inset Face Frame applications.
- All component parts of an assembled product will have a size tolerance of +/- 2mm.

► **For PRICING** ► See **Section A.1** in our current Wholesale Pricing Catalog.

1-800-237-1326

WalzCraft[®]

www.WalzCraft.com



Natural & Light Stain Colors

- We recommend a Select/Premium grade of material for products finished in a natural tone or light stain color.
- Select/Premium grades have a higher level of color & grain match. Please see the “Wood Species” descriptions in the back of this catalog for a detailed explanation of Select/Premium grades.
- Please reference **Special Notes about Cherry, Eucalyptus, Mahogany Products* in the wood species descriptions in the back of the catalog, for suggestions in dealing with the effects of natural photosensitivity of these products.

Spray No Wipe Stains

WalzCraft **highly** recommends using a “Spray No Wipe” stain process on Maple (*Hard & Soft*), Birch, Cherry and Pine for a more consistent “blotch free” look.

Engineered Stain / Paint Relief Cut

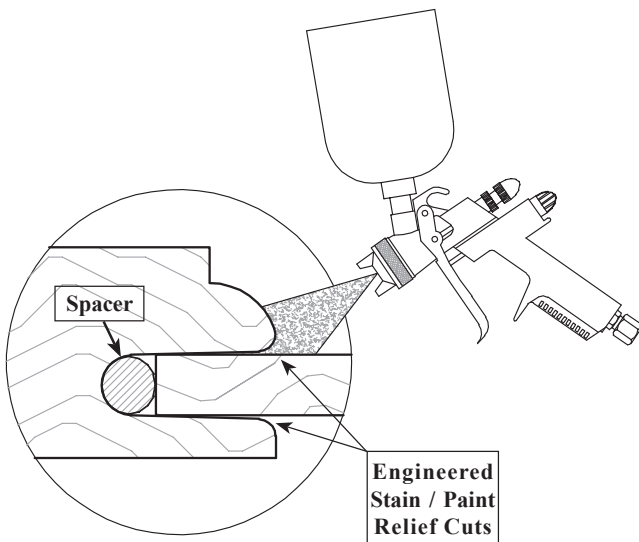

This engineered relief cut allows the finish to flow underneath the stile & rail profile, helping to prevent raw material from becoming exposed during the natural process of expansion and contraction in the center panel.

Please see page A.4.7 for further information pertaining to expansion and contraction of center panels in all cabinet components.

Painted Products (SolidTone®)

- **MDF is highly recommended for painting and for use with our SolidTone® colors.**
- MDF is very stable and does not incur the same seasonal expansion and contraction issues that can develop at the joints on hardwood doors, such as hairline cracks.
- If a hardwood door is preferred, consider using a Paint Grade of Cherry, Birch, Maple, or Poplar for your Stiles and Rails with an MDF center panel (Hybrid).
 - With MDF center panels you will avoid the potential for variances in stave thickness or sunken glue joints due to expansion and contraction.
- **For best results, we recommend ordering Maple due to the natural grain characteristics of this material.** (*Less grain is likely to show through after painting.*)
- When painting cherry, no attempt will be made to conceal any of the naturally occurring characteristics that may be present, including but not limited to pin knots and gum pockets. Please note that if not sealed properly, gum pockets may bleed through your finish.
- See “Finishing Methods” for more information on prefinishing MDF with “Primed Only for Paint” or “SolidTone® Colors”.

Final Finish Sanding (Prior to Finishing)

- All Finish Sanding is included in our pricing structure.
 - *The WalzCraft standard is to finish / fladder sand all of its products to at least a 180 grit.*
- Most WalzCraft doors are orbital sanded on the front and back. All cross grain scratches are removed from the face of each door only.
- Each door is then fladder sanded / denibbed on the front and back to remove any raised grain and to lightly break any sharp edges *which keep our quality standards at a consistently high level.*
- We **highly** recommend that you **block sand or sponge sand** all of your door faces and outside edge profiles to the same grit that you have sanded your face frames & cabinet boxes. This process should help you achieve a closer color match during your finishing process and will also remove any scuff marks, finger prints or scratches that may have occurred during handling, shipping and receiving of the product.

► For PRICING ► See Section A.1 in our current Wholesale Pricing Catalog.

Configuration = Customization

- WalzCraft's Configurator is the software engineering tool we use that allows us to customize and tailor product to your exact specifications.
- "Configuration" results in precision & efficient production.
- Our configuration software allows us to combine *over*:
 - 115 grades of lumber
 - 75 stile & rail profiles
 - 150 panel profiles
 - 200 outside edge profiles
 - 65 finish colors
 - 34 3D Laminate (RTF) colors
- WalzCraft provides you with thousands of customization options which allow for the creation of *millions* of designs - all from a single, reliable vendor.

Custom Engineered Products

- If you cannot find a product or component design to fit your project within our catalog, WalzCraft can create custom engineered products to match/replicate the existing specifications from your project.
- **Please note that additional charges may apply.** Due to their complexity, certain designs carry additional set up and engineering charges, which are reviewed on a per order basis.
- Examples of items that may require customization are doors, complex wainscot panels, angled components, etc.
- Requests can be submitted to our Customer Support Team for consideration by Research & Development/Custom Engineering prior to manufacturing.
- Please use any of the following methods to supply us with the necessary information:
 - **Call** our Customer Support Team to discuss your design.
 - **Fax** or **Email** your requests to our Customer Support Team.
 - **Email** a CAD file in either .dwg or .dxf format.
 - **Mail** a dimensioned drawing that has been printed to full scale.
 - **Ship** us a physical sample of the door, drawer front, etc.
- WalzCraft will facilitate final engineering for your approval. We reserve the right to modify any product to meet our manufacturing standards.
- **Products that require custom engineering are quoted and will require a final signature authorizing approval prior to proceeding with the project.**
- Wait-Times for *custom engineered products* cannot be determined until all engineering details are agreed on by WalzCraft and the customer. Once questions are answered and manufacturing guidelines are defined, our Production Scheduling Team will estimate the Wait-Time and schedule your project.
- **We reserve the right to decline requests for quotations or decline orders based on complexity and/or our current workload.**

Custom Engineered Profiles

- WalzCraft can custom engineer profiles to match/replicate those of existing products within your project.
- Before sending in a request to have a profile custom engineered, we ask that you first look through our catalog for a close match to your existing profile.
 - All profile drawings in *Chapter E, Chapter N* and *Chapter V* are shown at full scale.
 - There can be a significant time and cost savings in using a profile from our catalog vs. having a profile custom engineered.
- If a suitable match cannot be found, please use any of the following methods to supply us with the necessary information for custom engineering your profile:
 - **Email** a CAD file in either .dwg or .dxf format.
 - **Mail** a dimensioned drawing that has been printed to full scale.
 - **Ship** us a physical sample of the profile, molding, door, drawer front, etc.
 - Faxing is not an acceptable method of transmitting data for matching profiles. The scale and proportion of drawings that are faxed can be compromised during transmission given equipment settings; the drawings may not truly represent your vision.
- WalzCraft will facilitate final engineering for your approval. We reserve the right to modify any profile/prototype to meet our manufacturing standards.
- In cases where custom tooling needs to be created to achieve the requested profile / look, custom engineering charges may apply and the custom tooling will remain the property of WalzCraft.

Customer Requested Drawings

WalzCraft will sometimes produce CAD drawings for products that require customer approval. Should a customer request that drawings be produced when they are not required by WalzCraft, additional charges may apply.

New Products

- New products/options are commonly added weekly. Please contact our Customer Support Team if there is something you are looking for and it does not appear in this catalog.
- New product development is orchestrated by our Research and Development and Custom Engineering Team.

For the most up to date product information, please refer to our website at www.WalzCraft.com.

► **For PRICING** ► See Section A.1 in our current Wholesale Pricing Catalog.



Refacing Products

WalzCraft offers Cabinet Doors, Drawer Fronts, Drawer Boxes, Sheet Stock, Refacing Stock, Moldings, Valances and other Accent Accessories for Cabinet Refacers.

- Available Prefinished or Unfinished.
- Complete line of MDF products for priming/painting.
- Complete line of MDF/3D Laminate (RTF) products.

Redooring / Refronting

- Terms used in our industry when only the doors and drawer fronts are being replaced on a cabinet.
- Environmentally friendly options, as less material ends up in a landfill.
- Cost effective alternative to refacing or total cabinet replacement.

Kitchen & Bathroom Standards

For the latest information and industry standards for kitchen and bath cabinets, WalzCraft recommends that you visit the National Kitchen & Bath Association (NKBA) at NKBA.org. There you will find several publications that define what they consider to be industry standard dimensions and other specifications. WalzCraft can then, as a custom cabinet component manufacturer, build to your specifications, no matter what your requirements may be.

Outsourced Products OS

The following products are outsourced from other vendors, and in some cases are incorporated into the construction of the final WalzCraft product:

Applied Molding.....	E.8
Designer Glass	G.1
Leaded Glass	G.2
Glass Shelves	G.3
Wire Mesh.....	G.4
Cane/Wicker Center Panels.....	G.5
Lattice Material.....	G.6
Salice Hinges	I.1
Salice Drawer Slides	I.2
Hardware Screws and Miscellaneous Hardware.....	I.3
Drawer Slides - Side Mount.....	I.4
Blum Compact Face Frame Hinges	I.5
Blum Compact BLUMOTION Face Frame Hinges	I.6
Blum CLIP top Long Arm Hinges	I.7
Blum CLIP top BLUMOTION Long Arm Hinges	I.8
Blum TANDEM plus BLUMOTION Drawer Slides	I.9
Appliance Garage Kits.....	M.10
Tambour Door & Track System	M.11
Floating Shelves.....	M.17
Molding.....	N.13
Corbels	O.2
Legs/Posts - Stock Sizes	O.3
Create-A-Molding Inserts	O.5
Create-A-Column.....	O.6
Bun Feet	O.11
Outlet & Vent Covers.....	O.13
Range Hoods/Ventilation Units.....	P
Wall Mounted Sample Door Display Kit.....	T.3
Door/Drawer Front Carrying Cases	T.4

► **For PRICING** ► See Section **A.1** in our current Wholesale Pricing Catalog.

General Warranty

- WalzCraft warrants that its products are manufactured and sold free from defect for up to one year from the date of shipment.
- WalzCraft **does not** consider *natural* characteristics in wood to be defects (*burls, grain patterns, pin knots, mineral, sap, etc.*).
- Due to the *natural* characteristics of wood, it is impossible to warrant product to be free of cracks, splits, warps or discoloring if stored 2 weeks beyond the date received without properly sealing or top coating. WalzCraft recommends finishing all surface areas upon receipt.
- Some species, particularly Cherry, Eucalyptus and Mahogany, will darken naturally with age. WalzCraft will not be liable for product with any change in appearance, finished or unfinished, due to the aging process or natural photosensitive darkening processes. WalzCraft advises that you finish these products immediately upon receiving.
- Wood products expand and contract; thus tolerances have been engineered into all of our wood products which provide an allowance for normal movement in a controlled indoor environment.
- Storing products around, or in direct contact with moisture, can cause expansion of component parts that is far greater than engineered ranges would normally allow. This expansion forces joints to open and/or causes permanent joint failure in all wood products.
- **WalzCraft will not warrant any product that has been stored in a humid environment and/or subjected to moisture in any way.**
- **WalzCraft will not warrant any defects that could have been prevented by the customer, such as improper surface prep for a product that is to be finished.**
- **WalzCraft will not be liable for damage done to product due to improper handling and cleaning.**
- This warranty covers only the replacement of product produced by WalzCraft and shipping charges to and from our facility.
- This warranty does not cover any installation or removal, labor or travel time of any kind, nor any related products used with our products.
- To minimize the risk of damage in transit, we may recommend using a crate to package some items being shipped via Small Package Carrier, due to the size and the degree of complexity and/or difficulty to manufacture. **WalzCraft will not warrant product against shipping damage should you deny the use of a crate.** The customer will be liable and bears sole responsibility for the cost of such remakes and/or any replacement of component parts.
- All WalzCraft products are manufactured in La Crosse, WI with the exception of some outsourced components.
- **WalzCraft will not warrant any defects due to modification, alteration or service performed by anyone other than WalzCraft's production team.**

Warranty on Door Joints

- **WalzCraft will not warrant product that has been stored in an environment with high humidity or has been left improperly prepped and unfinished beyond 2 weeks from the delivery date.**
- Door joints may expand and contract to adapt to humidity changes within the environment. These changes make door joints susceptible to visible hairline cracks, of which we consider to be normal. These hairline cracks may be more or less visible depending on finish type applied.
- We recommend all wood products purchased from WalzCraft be kept in a controlled environment throughout the year, where the relative humidity level is maintained between 30% to 40% at all times.

Warranty on Glued Up Panel Expansion/Contraction

Due to the inherent expansion and contraction of wood, any product with a solid wood glued up panel, where the individual panel measures more than 24" [609.6mm] across the grain or 48" [1219.2mm] measured with the grain, will carry no warranty. This includes, but is not limited to:

- | | |
|---------------------------|--------------------------------|
| ◦ Raised Panel Doors | ◦ Glued Up Panels |
| ◦ Slab & Batten Doors | ◦ Center Panels Only |
| ◦ Slab & RP Drawer Fronts | ◦ Raised Panel Arched Valances |
| ◦ Wainscot Panels | ◦ Toe Kick Valances |
| ◦ Appliance Panels | ◦ Upper Cabinet Valances |

Because individual staves within a solid wood glued up panel will *naturally* continue to expand and contract, lines may appear and offsets may develop from one stave to another. These are not considered to be a defect.

Warranty on Solid Wood Slabs with Applied Molding

Solid wood slab doors and drawer fronts (Example: Style 1270) with applied molding that measure more than 10" [254mm] across the grain will carry no warranty.

Warranty on Applied Molding Attached by Others

WalzCraft will not warrant product that has had a molding glued or pinned to the center panel. Applied moldings that are pinned or glued to a center panel will not allow for proper expansion and contraction of the wood.

Warranty on Solid Wood Moldings

Due to the manufacturing process, solid wood moldings may differ in color from a solid wood glued up panel or other solid wood components of the same species used to produce a door.

► For PRICING ► See Section A.1 in our current Wholesale Pricing Catalog.



Warranty on Warping**Solid Wood**

- A 1/8" [3.2mm] warping tolerance is considered to be acceptable on all products with solid wood glued up components where the overall product measures up to 15" [381.0mm] across the grain or 48" [1219.2mm] measured with the grain.
- A 1/4" [6.4mm] warping tolerance is considered to be acceptable on all products with solid wood glued up components where the overall product measures more than 15" [381.0mm] up to 24" [609.6mm] across the grain or more than 48" [1219.2mm] up to 72" [1828.8mm] measured with the grain.
- Any product with solid wood glued up components, where the overall product measures more than 24" [609.6mm] across the grain or 72" [1828.8mm] measured with the grain, will carry no warranty against warping.
- Adding a center stile or center rail to products with oversized center panels (see **Section A.5**) will help minimize warping.
- Any **GUPFS** that measures more than 24" [609.6mm] across the grain or 72" [1828.8] measured with the grain will carry no warranty against warping.
- Any **Center Panel Only** that measures more than 24" [609.6mm] across the grain or 72" [1828.8] measured with the grain will carry no warranty against warping.

MDF

- A 1/8" [3.2mm] warping tolerance is considered to be acceptable on any MDF product where the overall product measures up to 15" [381.0mm] wide or 48" [1219.2mm] high.
- A 1/4" [6.4mm] warping tolerance is considered to be acceptable on any MDF product where the overall product measures more than 15" [381.0mm] up to 24" [609.6mm] wide or more than 48" [1219.2mm] up to 72" [1828.8mm] high.
- Any MDF product that measures more than 24" [609.6mm] wide or 72" [1828.8mm] high will carry no warranty against warping.
- MDF products included in these warping tolerances are raw MDF sheet stock, Style 60 doors and drawer fronts, raw 1-Piece MDF doors and drawer fronts and 1-Piece MDF /3D Laminate doors and drawer fronts.

Warranty on Twisting

An example of twisting is when a door laying on a flat surface has one corner that is slightly raised above the surface.

Solid Wood

- A 1/8" [3.2mm] twist tolerance is considered to be acceptable on all solid wood products that measure up to 48" [1219.2mm] with the grain.
- A 3/16" [4.8mm] twist tolerance is considered to be acceptable on all solid wood products that measure more than 48" [1219.2mm] up to 60" [1524mm] with the grain.
- There will be **no twist warranty** on products that measure more than 60" [1524mm] with the grain.

MDF

- A 1/8" [3.2mm] twist tolerance is considered to be acceptable on all MDF products that measure up to 48" [1219.2mm] high.
- A 3/16" [4.8mm] twist tolerance is considered to be acceptable on all MDF products that measure more than 48" [1219.2mm] high up to 60" [1524mm] high.
- There will be **no twist warranty** on MDF products that measure more than 60" [1524mm] high.
- See Warranty on Warping for included MDF products.

Warranty on Bowing (Barrel Effect)

- An example of bowing is when a door with vertical grain that is supposed to be 18" [457.2mm] wide measures 18" [457.2mm] wide at the top and bottom but measures 18 1/4" [463.6mm] in the middle. This is also sometimes referred to as a "barrel effect" and can occur due to the swelling of any wood component as a result of extreme moisture absorption.
 - Doors that measure more than 48" [1219.2mm] with the grain that are ordered **without** a center stile or center rail will have no warranty against bowing.
 - This includes wood frame only doors, wood frame & mullion doors, 5-Piece MDF frame only doors and 1-Piece MDF/3D Laminate frame only doors.
 - This does not include 1-Piece MDF/3D Laminate doors with center panels, as they are not susceptible to bowing.
 - Due to the nature of a miter joint, any expansion that a door or drawer front experiences due to the absorption of moisture may result in width and/or height bowing. Mitered doors and drawer fronts of any size will have no warranty against bowing.
 - If in extremely dry or humid regions, WalzCraft recommends the use of French Miter doors & drawer fronts. The door will be less likely to "barrel" than a traditional miter door.
- Any product with solid wood glued up components, where the overall product measures more than 72" [1828.8mm] with the grain (with or without a center stile or center rail), will carry no warranty against bowing.
 - This includes 5-Piece MDF Mortise & Tenon doors.
- Adding a center stile or center rail in doors that measure more than 48" [1219.2mm] with the grain will add stability and minimize bowing.
- WalzCraft **will not** automatically add a center stile or center rail.

Warranty on Convex/Concave Doors & Drawer Fronts

- WalzCraft will extend the same warranties as noted for expansion/contraction, warping, bowing and twisting to all convex/concave doors and drawer fronts.
 - Convex/Concave products must be stored and installed in a climate controlled environment. Failure to do so may result in warpage or twisting.
 - Unfinished convex/concave products should be stored in a climate controlled environment and finished as soon as possible after receipt.

Warranty on Passageway Doors

- WalzCraft will extend the same warranties as noted for expansion/contraction, warping, bowing and twisting to all passageway doors up to and including 80" [2032mm] measured with the grain, rather than the 72" [1828.8mm] limitation noted for warping and bowing.
 - Door Styles #8505 and #8605 are the **only exceptions** due to passageway door construction and minimum size requirements. These door styles do not use a center rail.
 - Passageway doors have an allowable 1/4" [6.4mm] warping tolerance.

► **For PRICING** ► See Section A.1 in our current Wholesale Pricing Catalog.

Warranty on Veneered Products

- Veneered panel doors are not guaranteed to match the solid wood stiles and rails on a door in either an unfinished or finished state. Veneers absorb stain differently than solid wood. The mismatch of solid woods and veneers is not considered to be a defect.
- Due to the nature of veneered materials, slight color variations may appear after finishing when compared to solid wood products.
- **WalzCraft makes every attempt to stain match between veneered and solid wood products on your project within an acceptable color range.** It is recommended that you stand at least 6 to 8 feet away from finished product when viewing.
- When refacing, solid wood stock should be used on the fronts of cabinets for the best color match.
- Using a *"Spray No Wipe"* stain on **Maple (Hard & Soft), Birch, Cherry and Pine** doors and drawer fronts with a veneer center panel is recommended for a more consistent *"blotch free"* look.
- We recommend all Resin Back, Wood Back and Paper Back veneer, finished or unfinished, purchased from WalzCraft, be kept in a controlled indoor environment throughout the year where the relative humidity level is maintained between 30% to 40% at all times. This will help to prevent the veneer from becoming dry and brittle and possibly cracking during installation.

Warranty on Unfinished Products

- Due to the natural expansion and contraction process that can be expected in wood products, we suggest you properly seal unfinished products within 2 weeks of receipt. We recommend all wood products purchased from WalzCraft be kept in a controlled environment throughout the year, where the relative humidity level is maintained between 30% to 40% at all times.
- If you are applying finishing materials to any product supplied by WalzCraft, please inspect the product carefully prior to doing so. The application of finishing materials implies that you accepted the product as being suitable for finish. If in doubt of a product's suitability for finishing, we suggest you contact us or test the finish on one item rather than finishing an entire job.
- **If unfinished product needs to be remade, WalzCraft will not be liable for any costs related to finishing.**
- **Please note that stile and rail joints may open slightly during the yearly heating and cooling cycle. This movement is normal and will not be considered for a no charge remake.**

Warranty on Product Finished by WalzCraft

- When cleaning products that are prefinished by WalzCraft, we recommend using a cloth dampened with a mix of warm water and a mild dish detergent (ex: Dawn Dish Soap). Apply the mixture sparingly and be certain to wipe off any excess cleaner with a dry cloth.
 - Do not use harsh, chemical based products such as ammonia or bleach based cleaners.
 - Do not use cleaners which contain abrasives.
 - Do not apply too much pressure while cleaning. Excessive pressure can cause burnishing.
- If you choose to use a household cleaner or any type of liquid on your finished WalzCraft product, we highly recommend that the solution be applied sparingly and immediately wiped off. You should not allow any residue or liquid to remain on the product.
- **WalzCraft will not warrant products that have been exposed to harsh abrasive chemicals, solvents, extreme ultraviolet light and moisture.**
- With products finished by WalzCraft you can expect a minimal amount of wear and aging to occur over time. This can be accelerated depending on the maintenance of the product.

Warranty on Product Finished by Others

- WalzCraft products are engineered to allow for proper expansion and contraction of the center panel during changes in climatic conditions.
- When a center panel is not allowed to expand and contract as engineered, it can lead to the door warping or twisting. This can be caused on doors with solid wood center panels when finish, such as your top coat or SolidTone® (paint), is allowed to flow between the center panel and the stile/rail, essentially gluing the panel into place.
- **WalzCraft will not warrant product if the application of a stain, glaze or any other finishing materials hinders or does not adequately allow for proper expansion and contraction.**
- **WalzCraft will not warrant product that is improperly stored, prepped or left unfinished beyond 2 weeks from the date of delivery.**

Warranty on SolidTone® Products

Stile and rail joints on wood products may open slightly during the yearly heating and cooling cycle. This movement is normal and will not be considered for a no charge remake.

Warranty on 3D Laminate (RTF) Products

- High heat may cause the foil material to delaminate from the MDF core. We recommend that you inform your customer of this so efforts can be made to protect product from high temperatures.
- **WalzCraft will not warrant any product that has delaminated from exposure to high temperatures.**
- 3D Laminate (RTF) foil colorfastness is warranted for 1 year.
 - Prolonged exposure to steam may cause the foil to discolor and will not be covered by the warranty.
- All other provisions of the general warranty also apply to the 3D Laminate (RTF) doors.

► For PRICING ► See Section A.1 in our current Wholesale Pricing Catalog.



Warranty on Add-On Orders

Coordinating Wood or Veneer Color Between Orders

- The beauty of *natural* wood products does allow for natural characteristics of the species to show through. As well, some wood species naturally have a range of color. Walnut, Cherry and Mahogany are a few examples where the difference is most notable, but to some degree this is present in all wood species.
- The best way to maintain wood color consistency within a project is to order everything needed for that project at the same time, on one order. If that is not possible to do, the next best action you could take is to inform the Customer Support staff at WalzCraft that you are concerned about color consistency between two separate orders.
- If placing an order as an “add-on” to a previous order, or an order that is based off some sample materials that were ordered previously, WalzCraft **highly recommends** that you provide us with a sample of that project to help ensure color consistency.
- Given the fact that wood changes color as it ages and due to changes and improvements within our production and finishing process, **WalzCraft will not warrant matching wood grain color, wood grain patterns and finished colors from one order to the next.**

No Warranty on Products Used Outdoors

All WalzCraft products are intended for interior use only. There will be no warranty when any WalzCraft product is installed outdoors.

Feedback Welcome!!

At WalzCraft, we continually strive to become the very best custom cabinet component manufacturer in the USA. In doing so, we ensure that you are provided with top tier Customer Support, new products, options and services and are kept current with industry standards and trends. We encourage all of our customers to share their thoughts, concerns, ideas, and needs about our products, both the negative and the positive! After all, “We can’t fix it if we don’t know about it”. This applies both internally to our WalzCraft Team and externally to our customers. We welcome and appreciate any and all feedback, as it provides all of us with the opportunity to continually grow and improve. We have a saying around here, “If we listen to our customers, they’ll take us where we need to go”.

“Thank You”

Richard and Brad Walz

Contact Us!

- Customer Support Telephone Number 1-800-237-1326
 - Monday - Friday: 6:00AM - 5:30PM (CST)
- Customer Support Fax (24 Hour)..... 1-608-781-3667
- Product and Catalog Questions/Feedback Email..... customersupport@WalzCraft.com
- Website (Main)..... http://www.WalzCraft.com
 - Customer Feedback button at top of the page

MAIL TO: WalzCraft
P.O. Box 1748
La Crosse, WI 54602-1748

SHIP TO: WalzCraft
2600 Hemstock Street
La Crosse, WI 54603-2349

Copyright

© Copyright 1982-2022, WalzCraft

► For PRICING ► See Section A.1 in our current Wholesale Pricing Catalog.



99.7% American Made

