



Style 100HB
in Cherry
with Drawer Box
"Scoop"



Style 100HB
in Walnut
with DBSP100 & Drawer
Box "Scoop"



Style 100HB
in Maple
with DPB202



Style 100HB
in Beech with
DBOI204 Insert

Drawer Box Options - Table of Contents

Section #	Section Name / Contents	Page #
H.1	Drawer Box Style 100HB - Half Blind Dovetail	H.1.2
H.2	Drawer Box Style 100F/T - Full/Through Dovetail	H.2.1
H.3	Drawer Box Style 100FR - French Dovetail	H.3.1
H.4	Drawer Box Style 100DW - Doweled (Plywood)	H.4.1
H.5	Drawer Box Style 100DW - Doweled (Melamine)	H.5.1
H.6	Drawer Box Bottom Panels	H.6.1
H.7	Drawer Slide Notching	H.7.1
	◦ NHH1 - Notch & Hook Hole Combination	H.7.1
	◦ Drawer Slide Notching Options	H.7.3
	◦ Hot Melt / Glue Pattern Locations on Drawer Boxes	H.7.4
H.8	Shaped Side Patterns (DBSP)	H.8.1
H.9	Scoop Front Options (SC)	H.9.1
H.10	Drawer Box "Ear" Options	H.10.1
H.11	Hanging File Slots (HFS)	H.11.1
H.12	Accented Top Edge	H.12.1
H.13	Laser Engraving (LOGO)	H.13.1
H.14	Bread Box Slideback Lid Option (BBSL)	H.14.1
H.15	Notched Patterns (DBP)	H.15.1
H.16	Curved Front Patterns (DBP)	H.16.1
H.17	Inside Corner Patterns	H.17.1
H.18	Drawer Slide Blocking	H.18.1
H.19	No Glue-Up	H.19.1
H.20	Drawer Box Organizer Inserts (DBOI)	H.20.1
	◦ DBOI - 100 Series	H.20.1
	◦ DBOI - 200 Series	H.20.1
	◦ DBOI - 300 Series	H.20.2
	◦ DBOI - 400 Series	H.20.3
H.21	Drawer Box Side Material	H.21.1
H.22	Drawer Box Divider Stock	H.22.1
	◦ Drawer Box Divider Molding	H.22.2

Style 100HB - Half Blind Dovetail Drawer Boxes (Solid Wood & Baltic Birch)

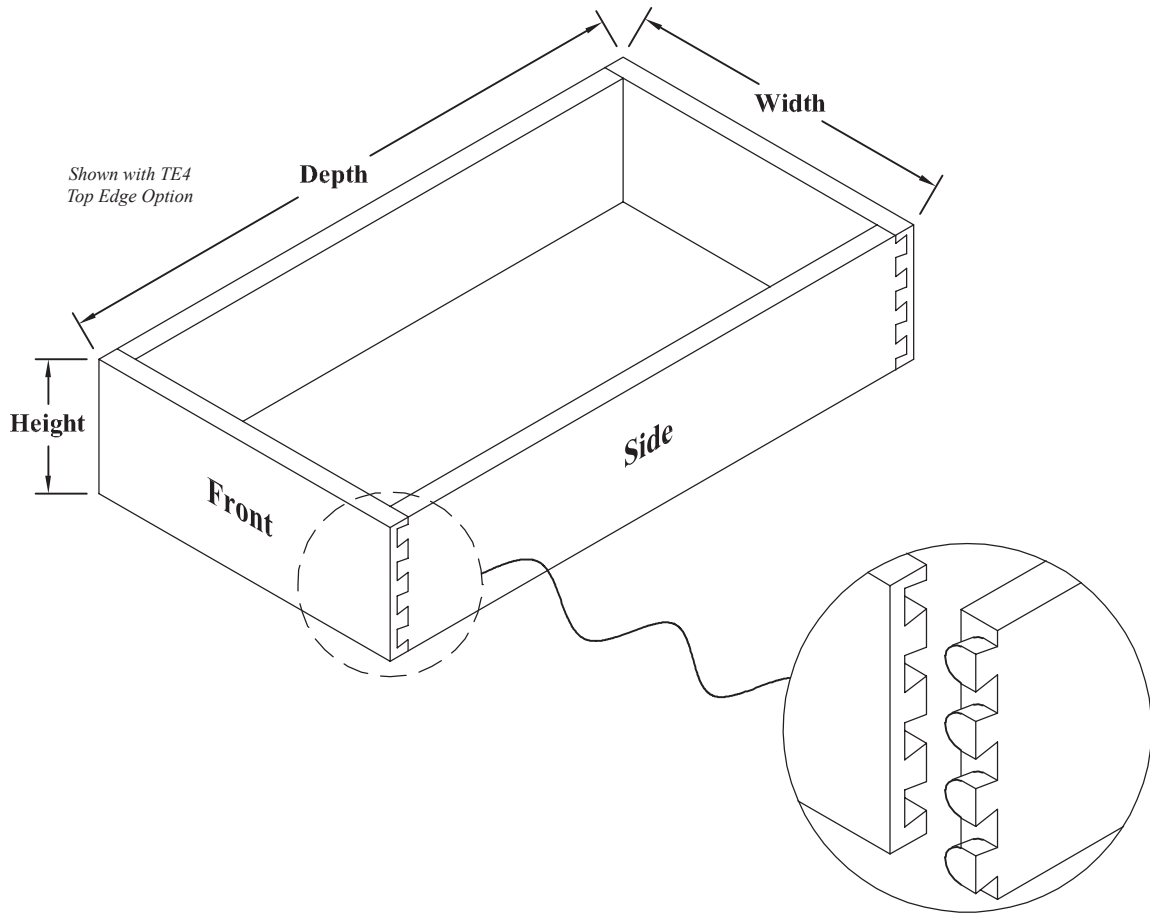

► For PRICING ► See Section *H.1* in our current Wholesale Pricing Catalog.

Style 100HB - Half Blind Dovetail Drawer Boxes - Top Edge Options

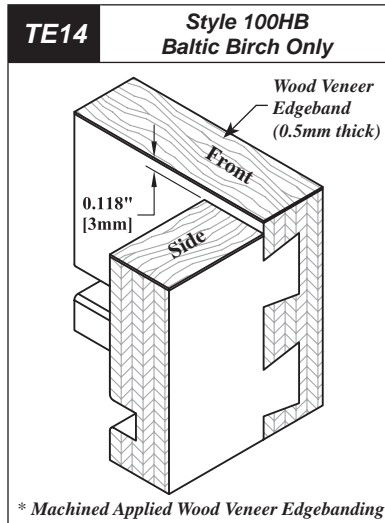
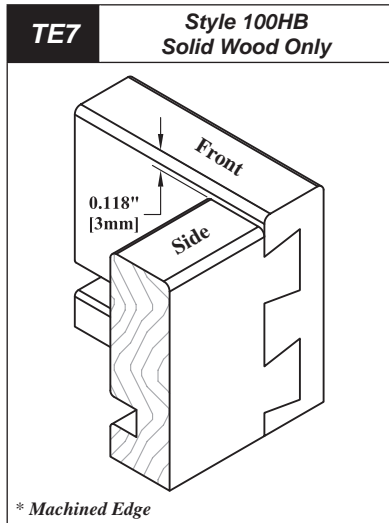
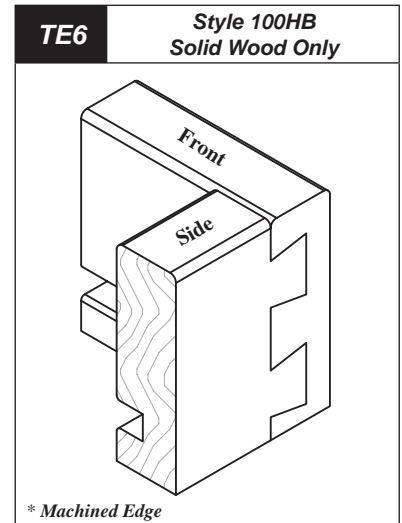
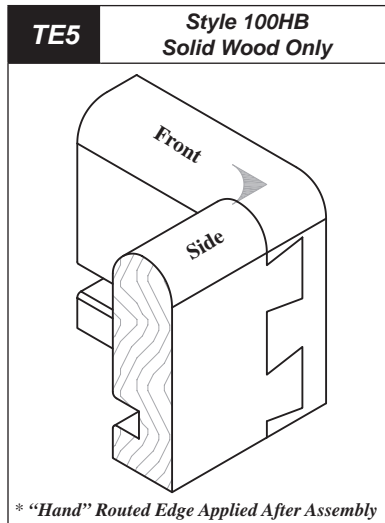
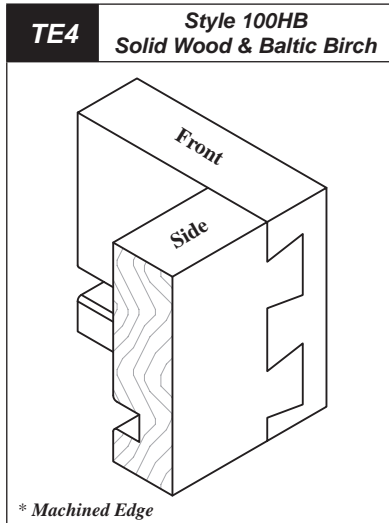
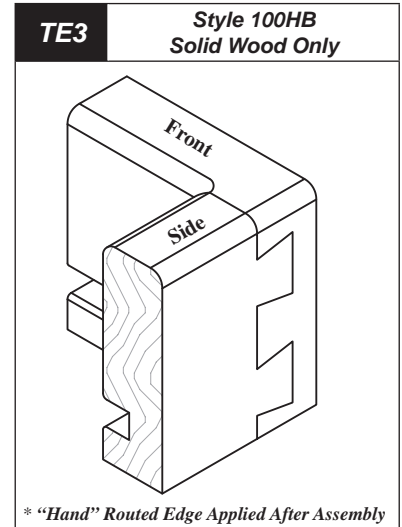
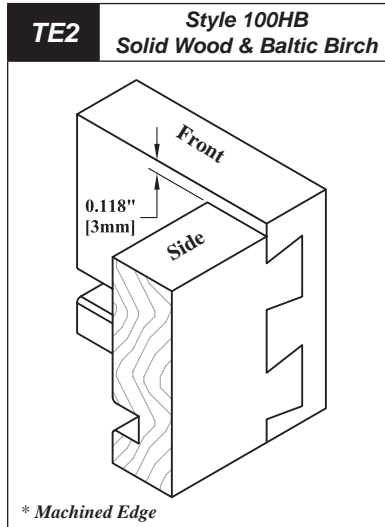
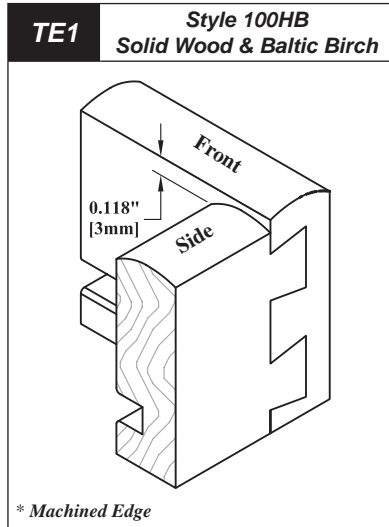

► **For PRICING** ► See Section *H.1* in our current Wholesale Pricing Catalog.

Drawer Box Options

Drawer Box Style 100HB - Half Blind Dovetail

Ordering & Pricing Notes: Style 100HB - Half Blind Dovetail Drawer Boxes

Ordering Guidelines

1	Order Forms	Please use <i>Drawer Box Order Form (E•Z Form #4)</i> .
		Some drawer box options will require the use of the “ <i>Advanced Version</i> ” of the form.
Pricing		
1	Sidewall Material	Please see <i>Section H.1</i> of our current Wholesale Pricing Catalog for pricing Front/Back/Sidewall material and Top Edge options.
2	Bottom Panel Material	Please see <i>Section H.6</i> of our current Wholesale Pricing Catalog for pricing Bottom Panel material.

Technical Notes: Style 100HB - Half Blind Dovetail Drawer Boxes

Required Options - Solid Wood - Assembled & RTA (Chapter H)

1	Top Edge Profiles	Assembled: Available with TE1, TE2, TE3, TE4, TE5, TE6, TE7 .
		Ready to Assemble (RTA): Available with TE1, TE2, TE4, TE6, TE7 .
2	Bottom Panel Inset	Assembled <i>and/or</i> Ready to Assemble (RTA): Available with all bottom panel inset options. See <i>Section H.6</i> . • Melamine bottom panels are not available with Bottom Mount or Flush Inset options.

Additional Options - Solid Wood - Assembled & RTA (Chapter H)

1	Drawer Slide Notching	Assembled: Available with all drawer slide notching options. See <i>Section H.7</i> .
		Ready to Assemble (RTA): Available with the DBN500 drawer slide notching option. See <i>Section H.7</i> .
2	Shaped Side Patterns	Assembled <i>and/or</i> Ready to Assemble (RTA): Available with all shaped side patterns. See <i>Section H.8</i> .
3	Scoop Fronts	Assembled <i>and/or</i> Ready to Assemble (RTA): Available with all scoop front options. See <i>Section H.9</i> .
4	Ears	Assembled <i>and/or</i> Ready to Assemble (RTA): Available with ears. See <i>Section H.10</i> .
5	Hanging File Slot	Assembled <i>and/or</i> Ready to Assemble (RTA): Available with all hanging file slot options. See <i>Section H.11</i> .
6	Accented Top Edge	Assembled <i>and/or</i> Ready to Assemble (RTA): Available with accented top edge. See <i>Section H.12</i> .
7	Laser Engraving	Assembled <i>and/or</i> Ready to Assemble (RTA): Available with laser engraving. See <i>Section H.13</i> .
8	Bread Box Slideback Lid	Assembled: Available with bread box slideback lid. See <i>Section H.14</i> .
		Ready to Assemble (RTA): Not available with bread box slideback lid.
9	Notched Patterns	Assembled: Available with all notched patterns. See <i>Section H.15</i> .
		Ready to Assemble (RTA): Not available with any notched patterns.
10	Curved Front Patterns	Assembled: Available with all curved front patterns. See <i>Section H.16</i> .
		Ready to Assemble (RTA): Not available with any curved front patterns.
11	Inside Corner Patterns	Assembled: Available with all inside corner patterns. See <i>Section H.17</i> .
		Ready to Assemble (RTA): Not available with any inside corner patterns.
12	Drawer Slide Blocking	Assembled: Available with all drawer slide blocking for release clip options. See <i>Section H.18</i> .
		Ready to Assemble (RTA): Not available with any drawer slide blocking for release clip options.
13	No Glue-Up Option	Assembled <i>and/or</i> Ready to Assemble (RTA): Available with the No Glue-Up Option. See <i>Section H.19</i> .

Required Options - Baltic Birch - Assembled & RTA (Chapter H)

1	Top Edge Profiles	Assembled: Available with TE1, TE2, TE4, TE14 .
		Ready to Assemble (RTA): Available with TE1, TE2, TE4, TE14 .
2	Bottom Panel Inset	Assembled <i>and/or</i> Ready to Assemble (RTA): Available with all bottom panel inset options. See <i>Section H.6</i> .

Additional Options - Baltic Birch - Assembled & RTA (Chapter H)

1	Drawer Slide Notching	Assembled: Available with all drawer slide notching options. See <i>Section H.7</i> .
		Ready to Assemble (RTA): Available with the DBN500 drawer slide notching option. See <i>Section H.7</i> .
2	Shaped Side Patterns	Assembled <i>and/or</i> Ready to Assemble (RTA): Available with all shaped side patterns. See <i>Section H.8</i> .
3	Scoop Fronts	Assembled <i>and/or</i> Ready to Assemble (RTA): Available with all scoop front options. See <i>Section H.9</i> .
4	Ears	Assembled <i>and/or</i> Ready to Assemble (RTA): Not available with ears. See <i>Section H.10</i> .
5	Hanging File Slot	Assembled <i>and/or</i> Ready to Assemble (RTA): Not available with any hanging file slot option.
6	Accented Top Edge	Assembled <i>and/or</i> Ready to Assemble (RTA): Not available with accented top edge.

Notes continued on next page...

► For PRICING ► See *Section H.1* in our current Wholesale Pricing Catalog.



Technical Notes: Style 100HB - Half Blind Dovetail Drawer Boxes...continued

Additional Options - Baltic Birch - Assembled & RTA (Chapter H)...continued

7	Laser Engraving	Assembled and/or Ready to Assemble (RTA): Available with laser engraving. See Section H.13.
8	Bread Box Slideback Lid	Assembled and/or Ready to Assemble (RTA): Not available with bread box slideback lid.
9	Notched Patterns	Assembled: Available with all notched patterns. See Section H.15.
		Ready to Assemble (RTA): Not available with any notched patterns.
10	Curved Front Patterns	Assembled and/or Ready to Assemble (RTA): Not available with any curved front patterns.
11	Inside Corner Patterns	Assembled and/or Ready to Assemble (RTA): Not available with any inside corner patterns.
12	Drawer Slide Blocking	Assembled: Available with all drawer slide blocking for release clip options. See Section H.18.
		Ready to Assemble (RTA): Not available with any drawer slide blocking for release clip options.
13	No Glue-Up Option	Assembled and/or Ready to Assemble (RTA): Not available with the No Glue-Up Option.

Finish Options - Assembled and RTA (Chapter R)

1	Natural / Clear Coat (no stain)	<p>Assembled: Solid wood and baltic birch Half Blind Dovetail drawer boxes are available unfinished or finished with WalzCraft's <i>water base</i> "Natural / Clear Coat (<i>no stain</i>)" finish.</p> <ul style="list-style-type: none"> WalzCraft has used water base finish on assembled drawer boxes since 2009. Water base finish is Urea Formaldehyde Free. No finish is applied to the underside of drawer box. <ul style="list-style-type: none"> ◦ <i>Underside can be finished upon request, but additional charges will apply.</i>
		<p>Ready to Assemble (RTA): Solid wood and baltic birch Half Blind Dovetail drawer boxes are available unfinished or finished with Walzcraft's <i>solvent base</i> "Natural / Clear Coat (<i>no stain</i>)" finish.</p>
2	Primed Only for Paint	<p>Assembled: Solid wood Half Blind Dovetail drawer boxes are available with a "Primed Only for Paint" finish.</p> <ul style="list-style-type: none"> Not available when drawer boxes have melamine bottom panels. Only available on wood species noted in the SolidTone® finish grids in Section R.2. <ul style="list-style-type: none"> ◦ "Primed Only for Paint" drawer boxes utilizing WalzCraft's <i>catalyzed</i> primer are available in all SolidTone® colors. ◦ "Primed Only for Paint" drawer boxes utilizing WalzCraft's <i>non-catalyzed</i> primer are only available in white or gray. No gaps will be filled on the bottom panel or on inside corners. No finish will be applied to the underside of the drawer box. Drawer boxes with a "Primed Only for Paint" finish can only be packaged utilizing PM16 or PM17. <ul style="list-style-type: none"> ◦ Please see Section A.3 for more information on Packaging Methods.
		<p>Ready to Assemble (RTA): Solid wood Half Blind Dovetail drawer boxes are not available with a "Primed Only for Paint" finish.</p>
3	SolidTone®	<p>Assembled: Solid wood Half Blind Dovetail drawer boxes are available with a SolidTone® finish.</p> <ul style="list-style-type: none"> Not available when drawer boxes have melamine bottom panels. Only available on wood species noted in the SolidTone® finish grids in Section R.2. <ul style="list-style-type: none"> ◦ All SolidTone® colors are available. Available with Dry Wiped or Solvent Wiped glaze (Section R.3). <ul style="list-style-type: none"> ◦ Please note that the application of flow pen glaze is not available with drawer boxes. No gaps will be filled on the bottom panel or on inside corners. No finish will be applied to the underside of the drawer box. Drawer boxes with a SolidTone® finish can only be packaged utilizing PM16 or PM17. <ul style="list-style-type: none"> ◦ Please see Section A.3 for more information on Packaging Methods.
		<p>Ready to Assemble (RTA): Solid wood Half Blind Dovetail drawer boxes are not available with a SolidTone® finish.</p>

Hardware Options (Chapter I)

1	Drawer Slide Release Clips	Drawer box style 100HB is available with undermount drawer slide release clips/locking devices installed. Please see Chapter I of the Product Specifications Catalog for restrictions.
---	-----------------------------------	---

Material Options

1	Material	Half blind dovetail drawer boxes are available in solid wood and baltic birch plywood.
2	Budget / Value Grade	WalzCraft has established the grade " BG " to indicate a " Budget/Value Grade " of material. Budget grade materials include mineral, sap, small glue-ups (n/a with baltic birch), and other characteristics common in whatever species you order. The wood is structurally sound and a good value if you are able to use them in your project.

Notes continued on next page...

H

Technical Notes: Style 100HB - Half Blind Dovetail Drawer Boxes...continued

Miscellaneous

1	Hot Melt / Glue	Hot melt / glue is applied to the bottom of all assembled drawer boxes for added strength. This excludes boxes being built without bottom panels, boxes with bottom mount or flush inset bottom panels and boxes with DBN500 drawer slide notching. Please see Section H.7 for more information.
---	-----------------	---

Ready to Assemble (RTA)

1	Ready To Assemble	Solid wood and Baltic Birch half blind dovetail drawer boxes are available Ready to Assemble (RTA).
2	Customer Supplied Drawer Box Bottom	When ordering Ready to Assemble (RTA) drawer boxes and supplying your own bottom panel, please specify the Bottom Panel Inset Option (see Section H.6) and the width of the Dado Groove based on your bottom panel thickness. Dado Groove Widths: None, .225" [5.7mm], .250" [6.4mm], .450" [11.4mm], .500" [12.7mm].
3	Freight Costs	Ordering drawer boxes Ready to Assemble (RTA) may provide you savings in freight costs.

Sizes / Dimensions

1	Sidewall Thickness	Solid Wood: Available in ½" [12.7mm], ⅝" [15.9mm] and ¾" [19.1mm] thicknesses. Baltic Birch Plywood: Available in 12.5mm, 15.2mm, 18.0mm thicknesses.
2	Minimum & Maximum Sizes	Assembled and Ready to Assemble (RTA): Width: Minimum = 4¾" [120.7mm]. Maximum = 43" [1092.2mm]. Absolute Maximum = 60" [1524.0mm]. Depth: Minimum = 4¾" [120.7mm]. Maximum = 36" [914.4mm]. Absolute Maximum = 60" [1524.0mm]. Height: Minimum = 1¾" [44.5mm]. Maximum = 14½" [368.3mm]. Absolute Maximum = 30" [762.0mm]. Drawer boxes cannot exceed an absolute maximum depth of 48" [1219.2mm] when bottom panel grain direction is running left to right or a width of 48" [1219.2mm] when bottom panel grain direction is running front to back. The minimum height of a drawer box with a DB Organizer Insert (DBOI) varies. Please see Section H.20 for DBOI minimums and other relative dimensions. You must also factor in the bottom panel thickness and bottom panel inset option of the drawer box when calculating the drawer box minimum height. Assembled drawer boxes built between the Maximum and Absolute Maximum sizes will be subject to an "Oversized" Drawer Box Assembly Charge, due to special handling requirements. See Section H.1 of our current Wholesale Pricing Catalog for upcharges.
3	Dovetail Height	Dovetail size may vary due to the height of your drawer box, bottom panel thickness and bottom panel inset.

Top Edge Profile Options

1	"TE1" Top Edge	Constructed with the sides 3.0mm shorter than the front and back of the box. On ¾" [19.1mm] thick material, the sides are 4.0mm shorter than the front and back of the box. All edges are eased. When ordering, please give the height dimension using the size for the front and back.
2	"TE2" Top Edge	Constructed with the sides 3.0mm shorter than the front and back of the box. All edges are square. When ordering, please give the height dimension using the size for the front and back.
3	"TE3" Top Edge	Top edges are all flush and eased, except the face that attaches to the back of the drawer front.
4	"TE4" Top Edge	Top edges are flush and square on all sides.
5	"TE5" Top Edge	Top edges are flush and radiused to form a half circle, except the face that attaches to the back of the drawer front. A slight flat spot appears on the top where the joint meets.
6	"TE6" Top Edge	Top edges are slightly eased on all sides and flush except at the joints where the sides meet the front or back of the drawer box.
7	"TE7" Top Edge	Top edges are slightly eased on all sides and constructed with the sides 3mm shorter than the front and back of the box. When ordering, please give the height dimension using the size for the front and back.
8	"TE14" Top Edge	TE14 only available with Baltic Birch. Top edge option is constructed with the sides 3.0mm shorter than the front and back of the box and finished with a veneer edgeband 0.5mm thick. When ordering, please give the height dimension using the size for the front and back.

► For PRICING ► See Section H.1 in our current Wholesale Pricing Catalog.

Style 100F/T - Full/Through Dovetail Drawer Boxes (Solid Wood)

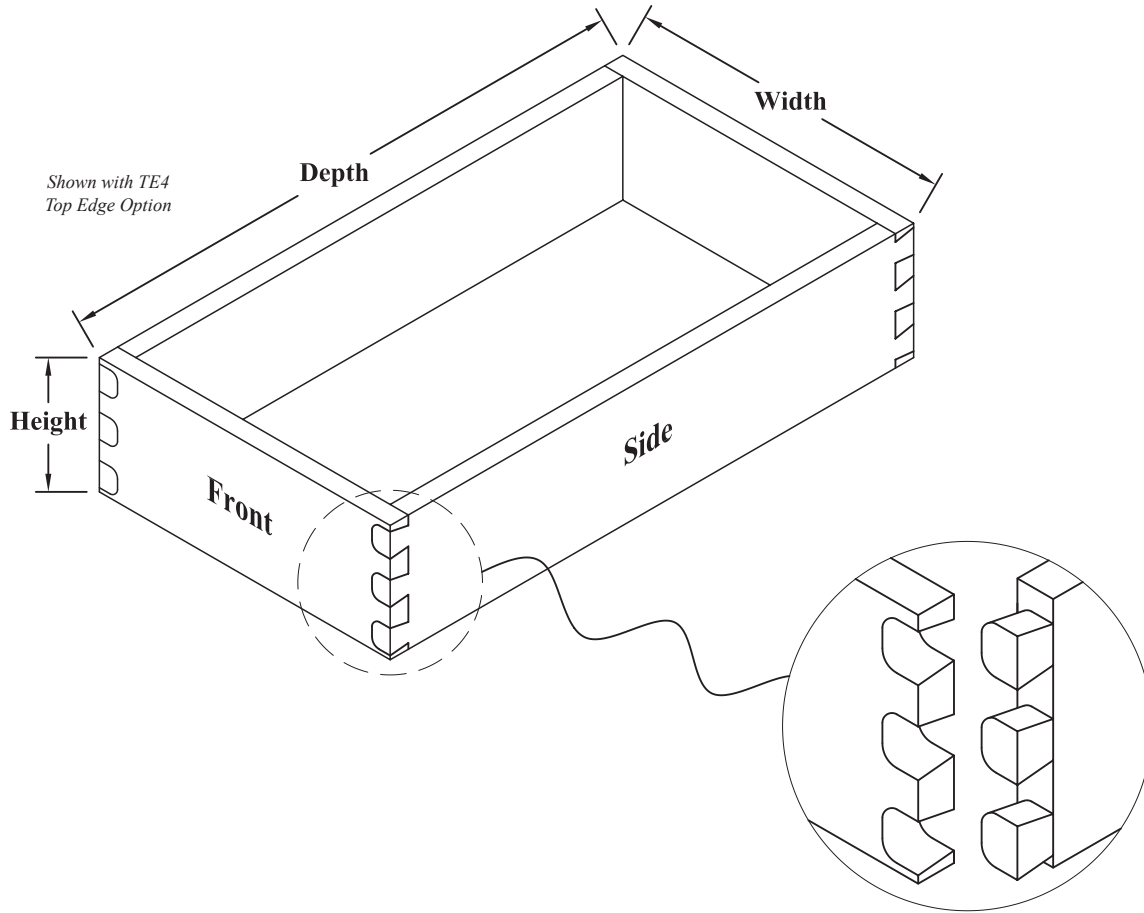

Full/Through Dovetail - Solid Wood



► For PRICING ► See Section **H.2** in our current Wholesale Pricing Catalog.

Style 100F/T - Full/Through Dovetail Drawer Boxes - Top Edge Options

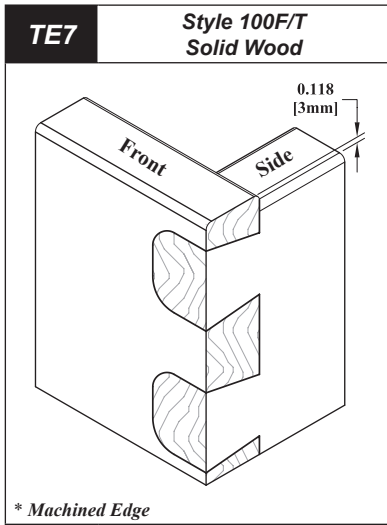
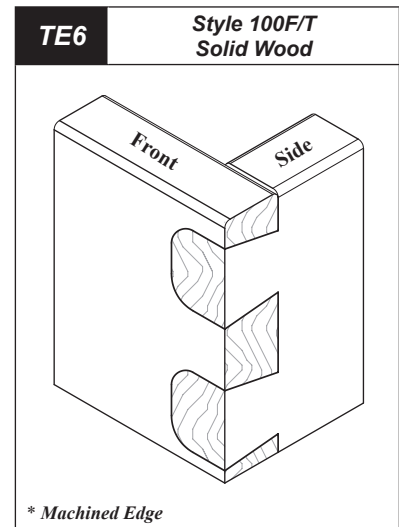
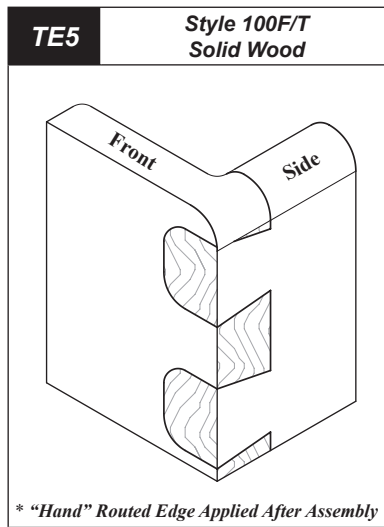
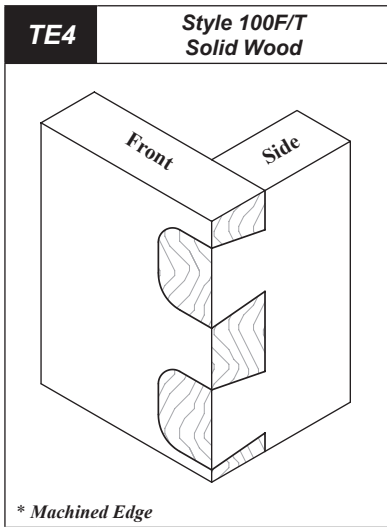
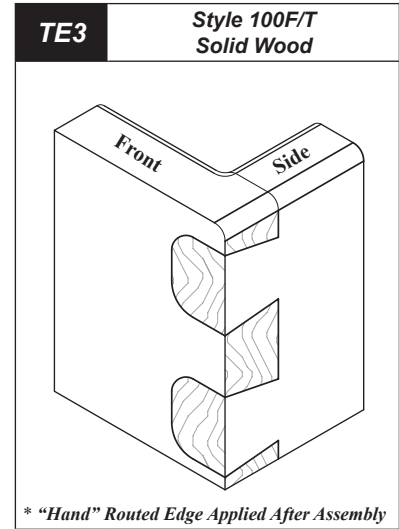
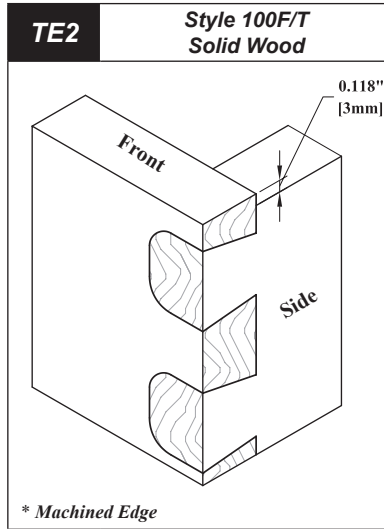
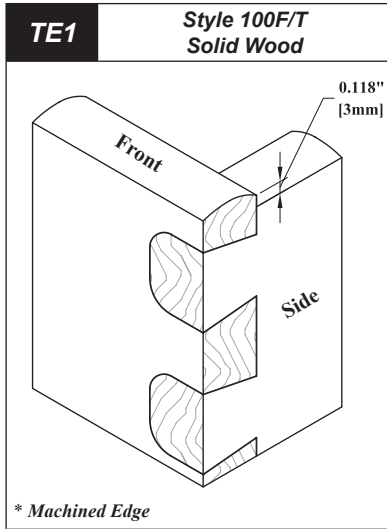

► For PRICING ► See Section H.2 in our current Wholesale Pricing Catalog.

Drawer Box Options

Drawer Box Style 100F/T - Full / Through Dovetail

Ordering & Pricing Notes: Style 100F/T - Full/Through Dovetail Drawer Boxes

Ordering Guidelines

1	Order Forms	Please use Drawer Box Order Form (E•Z Form #4) .
		Some drawer box options will require the use of the “ <i>Advanced Version</i> ” of the form.
Pricing		
1	Sidewall Material	Please see Section H.2 of our current Wholesale Pricing Catalog for pricing Front/Back/Sidewall material and Top Edge options.
2	Bottom Panel Material	Please see Section H.6 of our current Wholesale Pricing Catalog for pricing Bottom Panel material.

Technical Notes: Style 100F/T - Full/Through Dovetail Drawer Boxes

Required Options - Solid Wood - Assembled (Chapter H)

1	Top Edge Profiles	Assembled: Available with TE1, TE2, TE3, TE4, TE5, TE6, TE7 .
2	Bottom Panel Inset	Assembled: Available with all bottom panel inset options. See Section H.6 . • Melamine bottom panels are not available with Bottom Mount or Flush Inset options.

Additional Options - Solid Wood - Assembled (Chapter H)

1	Drawer Slide Notching	Assembled: Available with all drawer slide notching options. See Section H.7 .
2	Shaped Side Patterns	Assembled: Not available with any shaped side patterns.
3	Scoop Fronts	Assembled: Available with all scoop front options. See Section H.9 .
4	Ears	Assembled: Not available with ears.
5	Hanging File Slot	Assembled: Not available with any hanging file slot options.
6	Accented Top Edge	Assembled: Not available with accented top edge.
7	Laser Engraving	Assembled: Available with laser engraving. See Section H.13 .
8	Bread Box Slideback Lid	Assembled: Not available with bread box slideback lid.
9	Notched Patterns	Assembled: Not available with any notched patterns.
10	Curved Front Patterns	Assembled: Not available with any curved front patterns.
11	Inside Corner Patterns	Assembled: Not available with any inside corner patterns.
12	Drawer Slide Blocking	Assembled: Not available with any drawer slide blocking for release clip options.
13	No Glue-Up Option	Assembled and Ready to Assemble (RTA): Available with the No Glue-Up Option. See Section H.19 .

Finish Options - Assembled (Chapter R)

1	Natural / Clear Coat (no stain)	Assembled: Solid wood Full / Through Dovetail drawer boxes are available unfinished or finished with WalzCraft’s <i>water base</i> “Natural / Clear Coat (no stain)” finish. • WalzCraft has used water base finish on assembled drawer boxes since 2009. • Water base finish is Urea Formaldehyde Free. • No finish is applied to the underside of drawer box. ◦ <i>Underside can be finished upon request, but additional charges will apply.</i>
2	Primed Only for Paint	Assembled: Solid wood Full / Through Dovetail drawer boxes are not available with a “Primed Only for Paint” finish.
3	SolidTone®	Assembled: Solid wood Full / Through Dovetail drawer boxes are not available with a SolidTone® finish.

Hardware Options (Chapter I)

1	Drawer Slide Release Clips	Drawer box style 100FT is available with undermount drawer slide release clips / locking devices installed. Please see Chapter I of the Product Specifications Catalog for restrictions.
---	----------------------------	---

Material Options

1	Material	Full/Through dovetail drawer boxes are available in solid wood only.
2	Budget / Value Grade	WalzCraft has established the grade “ BG ” to indicate a “ Budget/Value Grade ” of material. Budget grade materials include mineral, sap, small glue-ups, and other characteristics common in whatever species you order. The wood is structurally sound and a good value if you are able to use them in your project.

Notes continued on next page...

► For PRICING ► See **Section H.2** in our current Wholesale Pricing Catalog.

Technical Notes: Style 100F/T - Full/Through Dovetail Drawer Boxes...continued

Miscellaneous

1	Hot Melt / Glue	Hot melt/glue is applied to the bottom of all assembled drawer boxes for added strength. This excludes boxes being built without bottom panels, boxes with bottom mount or flush inset bottom panels and boxes with DBN500 drawer slide notching. Please see Section H.8 for more information.
----------	------------------------	--

Ready to Assemble (RTA)

1	Ready To Assemble	Full/Through dovetail drawer boxes are not available Ready To Assemble (RTA).
----------	--------------------------	--

Sizes / Dimensions

1	Sidewall Thickness	Available in ½" [12.7mm], ⅝" [15.9mm] and ¾" [19.1mm] thicknesses.
2	Minimum & Maximum Sizes	<p>Assembled: Width: Minimum = 4¾" [120.7mm]. Maximum = 43" [1092.2mm]. Absolute Maximum = 60" [1524.0mm]. Depth: Minimum = 4¾" [120.7mm]. Maximum = 36" [914.4mm]. Absolute Maximum = 60" [1524.0mm]. Height: Minimum = 1¾" [44.5mm]. Maximum = 14½" [368.3mm]. Absolute Maximum = 30" [762.0mm].</p> <p>Drawer boxes cannot exceed an absolute maximum depth of 48" [1219.2mm] when bottom panel grain direction is running left to right or a width of 48" [1219.2mm] when bottom panel grain direction is running front to back.</p> <p>The minimum height of a drawer box with a DB Organizer Insert (DBOI) varies. Please see Section H.20 for DBOI minimums and other relative dimensions. You must also factor in the bottom panel thickness and bottom panel inset option of the drawer box when calculating the drawer box minimum height.</p> <p>Assembled drawer boxes built between the Maximum and Absolute Maximum sizes will be subject to an "Oversized" Drawer Box Assembly Charge, due to special handling requirements. See Section H.1 of our current Wholesale Pricing Catalog for upcharges.</p>
3	Full/Through Dovetail Height	Dovetail size may vary due to the height of your drawer box, bottom panel thickness and bottom panel inset.

Top Edge Profile Options

1	"TE1" Top Edge	<p>Constructed with the sides 3.0mm shorter than the front and back of the box. On ¾" [19.1mm] thick material, the sides are 4.0mm shorter than the front and back of the box.</p> <p>All edges are eased.</p> <p>When ordering, please give the height dimension using the size for the front and back.</p>
2	"TE2" Top Edge	<p>Constructed with the sides 3.0mm shorter than the front and back of the box.</p> <p>All edges are square.</p> <p>When ordering, please give the height dimension using the size for the front and back.</p>
3	"TE3" Top Edge	Top edges are all flush and eased, except the face that attaches to the back of the drawer front.
4	"TE4" Top Edge	Top edges are flush and square on all sides.
5	"TE5" Top Edge	<p>Top edges are flush and radiused to form a half circle, except the face that attaches to the back of the drawer front.</p> <p>A slight flat spot appears on the top where the joint meets.</p>
6	"TE6" Top Edge	Top edges are slightly eased on all sides and flush except at the joints where the sides meet the front or back of the drawer box.
7	"TE7" Top Edge	<p>Top edges are slightly eased on all sides and constructed with the sides 3mm shorter than the front and back of the box.</p> <p>When ordering, please give the height dimension using the size for the front and back.</p>

► For PRICING ► See Section H.2 in our current Wholesale Pricing Catalog.

Style 100FR - French Dovetail Drawer Boxes (Solid Wood)

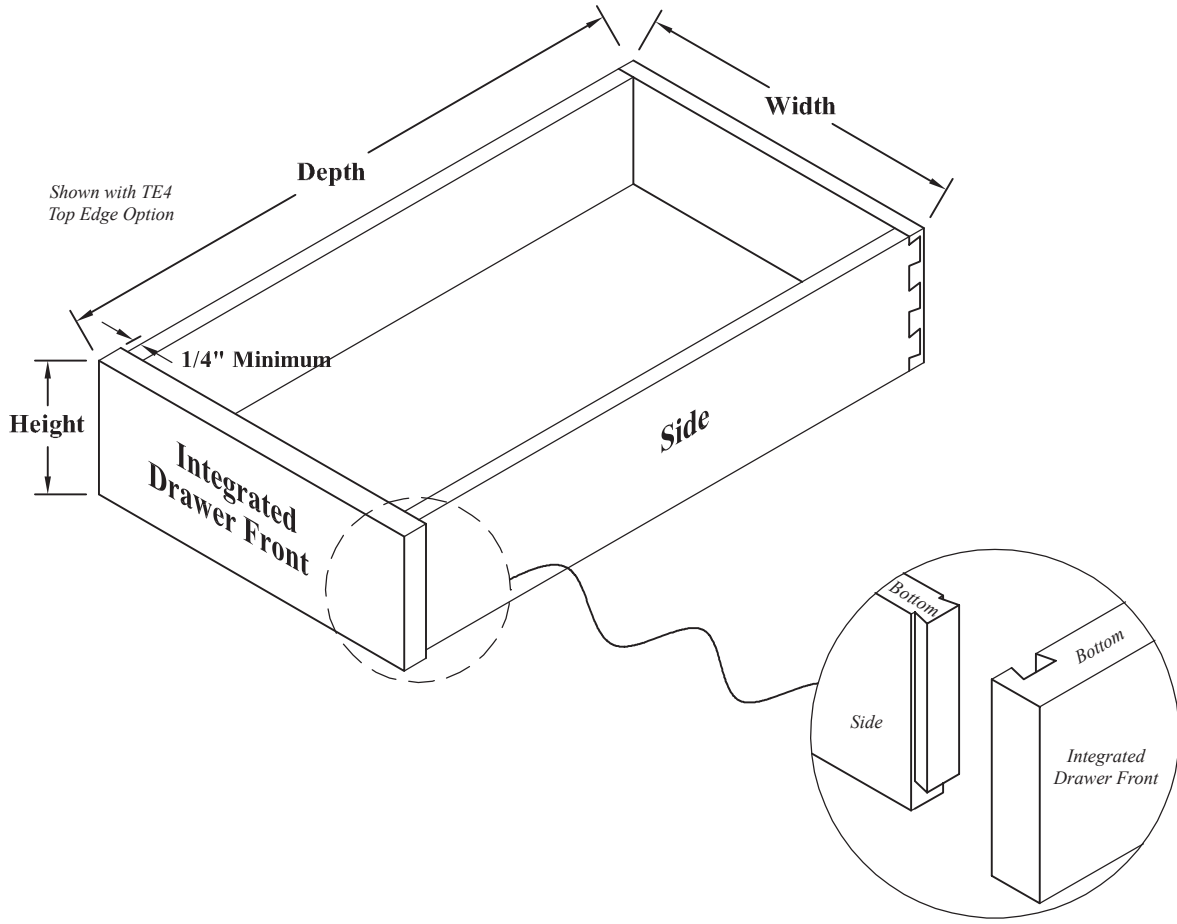

French Dovetail - Solid Wood

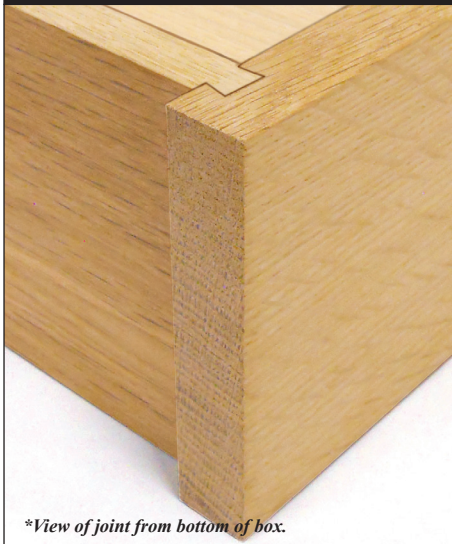

► For PRICING ► See Section **H.3** in our current Wholesale Pricing Catalog.

Style 100FR - French Dovetail Drawer Boxes - Top Edge Options

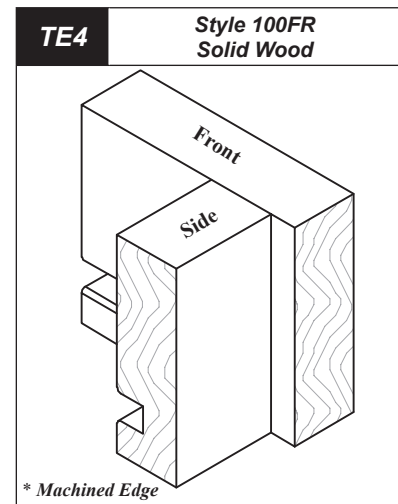
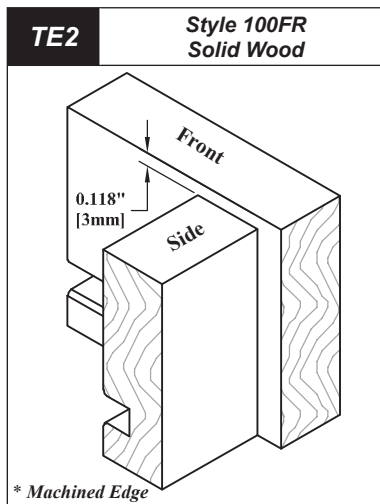
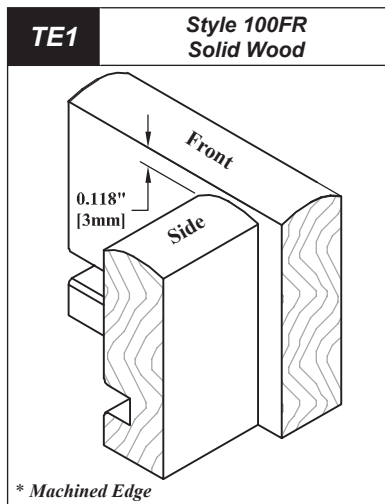

Ordering & Pricing Notes: Style 100FR - French Dovetail Drawer Boxes

Ordering Guidelines

1	Order Forms	Please use <i>Drawer Box Order Form (E-Z Form #4)</i> . Some drawer box options will require the use of the "Advanced Version" of the form.
2	Ordering Information	When ordering French Dovetail drawer boxes please specify: <ul style="list-style-type: none"> • Overall width at the back of the box. • Overall height at the back of the box. • Overall depth including integrated front. • Distance that the integrated front extends past the sides (minimum ¼"[6.4mm]). • Distance that the integrated front extends above the top of the sides (minimum 0"). • Distance that the integrated front extends below the bottom of the sides (minimum 0").
Pricing		
1	Sidewall Material	Please see <i>Section H.3</i> of our current Wholesale Pricing Catalog for pricing Front/Back/Sidewall material and Top Edge options.
2	Bottom Panel Material	Please see <i>Section H.6</i> of our current Wholesale Pricing Catalog for pricing Bottom Panel material.

Technical Notes: Style 100FR - French Dovetail Drawer Boxes

Required Options - Solid Wood - Assembled (Chapter H)

1	Top Edge Profile	Assembled: Available with TE1, TE2, TE4.
2	Bottom Panel Inset	Assembled: Available with all bottom panel inset options. See <i>Section H.6</i> . • Melamine bottom panels are not available with Bottom Mount or Flush Inset options.

Additional Options - Solid Wood - Assembled (Chapter H)

1	Drawer Slide Notching	Assembled: Available with all drawer slide notching options. See <i>Section H.7</i> .
2	Shaped Side Patterns	Assembled: Available with all shaped side patterns <i>except</i> DBSP300, DBSP400. See <i>Section H.8</i> .
3	Scoop Fronts	Assembled: Available with all scoop front options. See <i>Section H.9</i> .
4	Ears	Assembled: Not available with ears.
5	Hanging File Slot	Assembled: Not available with any hanging file slot options.
6	Accented Top Edge	Assembled: Not available with accented top edge.
7	Laser Engraving	Assembled: Available with laser engraving. See <i>Section H.13</i> .
8	Bread Box Slideback Lid	Assembled: Not available with bread box slideback lid.
9	Notched Patterns	Assembled: Not available with any notched patterns.
10	Curved Front Patterns	Assembled: Not available with any curved front patterns.
11	Inside Corner Patterns	Assembled: Not available with any inside corner patterns.
12	Drawer Slide Blocking	Assembled: Not available with any drawer slide blocking.
13	No Glue-Up Option	Assembled: Available with the No Glue-Up Option. See <i>Section H.19</i> .

Notes continued on next page...

Technical Notes: Style 100FR - French Dovetail Drawer Boxes...continued

Finish Options - Assembled (Chapter R)

1	Natural/Clear Coat (no stain)	<p>Assembled: Solid wood French Dovetail drawer boxes are available unfinished or finished with WalzCraft's <i>water base</i> "Natural/Clear Coat (<i>no stain</i>)" finish.</p> <ul style="list-style-type: none"> • WalzCraft has used water base finish on assembled drawer boxes since 2009. • Water base finish is Urea Formaldehyde Free. • No finish is applied to the underside of drawer box. <ul style="list-style-type: none"> ◦ <i>Underside can be finished upon request, but additional charges will apply.</i>
2	Primed Only for Paint	<p>Assembled: Solid wood French Dovetail drawer boxes are not available with a "Primed Only for Paint" finish.</p>
3	SolidTone®	<p>Assembled: Solid wood French Dovetail drawer boxes are not available with a SolidTone® finish.</p>

Hardware Options (Chapter I)

1	Drawer Slide Release Clips	<p>Drawer box style 100FR is available with undermount drawer slide release clips/locking devices installed. Please see <i>Chapter I</i> of the Product Specifications Catalog for restrictions.</p>
---	-----------------------------------	--

Material Options

1	Material	<p>French dovetail drawer boxes are available in solid wood only.</p>
2	Budget / Value Grade	<p>WalzCraft has established the grade "BG" to indicate a "Budget / Value Grade" of material. Budget grade materials include mineral, sap, small glue-ups, and other characteristics common in whatever species you order. The wood is structurally sound and a good value if you are able to use them in your project.</p>

Miscellaneous

1	Hot Melt / Glue	<p>Hot melt /glue is applied to the bottom of all assembled drawer boxes for added strength. This excludes boxes being built without bottom panels, boxes with bottom mount or flush inset bottom panels and boxes with DBN500 drawer slide notching. Please see <i>Section H.8</i> for more information.</p>
2	Edge Glued Side Walls	<p>When ordering solid wood French Dovetail drawer boxes in a Natural Grade or a Select Grade at 6" [152.4mm] high or under, the face/front of the drawer box will be made from one solid piece. The left side, right side and back may contain edge glued pieces. For heights over 6" [152.4mm], WalzCraft will use edge glued pieces wherever necessary.</p> <p>For all other wood species grades at any height, solid wood French Dovetail drawer boxes will contain edge glued pieces wherever necessary.</p> <p>See <i>Section H.19</i> for WalzCraft's No Glue-Up (NGU100) option for drawer box side walls.</p>

Ready to Assemble (RTA)

1	Ready To Assemble	<p>French dovetail drawer boxes are not available Ready To Assemble (RTA).</p>
---	--------------------------	--

Sizes / Dimensions

1	Sidewall Thickness	<p>Available in 1/2" [12.7mm], 3/8" [15.9mm] and 3/4" [19.1mm] thicknesses.</p>
2	Integrated Drawer Front Thickness	<p>French Dovetail drawer boxes are constructed using 3/4" [19.1mm] integrated drawer fronts. For other thicknesses, please contact our Customer Support Team.</p>
3	Minimum & Maximum Sizes	<p>Assembled: Width: Minimum = 4 3/4" [120.7mm]. Maximum = 43" [1092.2mm]. Absolute Maximum = 60" [1524.0mm]. Depth: Minimum = 4 3/4" [120.7mm]. Maximum = 36" [914.4mm]. Absolute Maximum = 60" [1524.0mm]. Height: Minimum = 1 3/4" [44.5mm]. Maximum = 14 1/2" [368.3mm]. Absolute Maximum = 30" [762.0mm].</p> <p>Drawer boxes cannot exceed an absolute maximum <i>depth</i> of 48" [1219.2mm] when bottom panel grain direction is running left to right or a <i>width</i> of 48" [1219.2mm] when bottom panel grain direction is running front to back.</p> <p>The minimum height of a drawer box with a DB Organizer Insert (DBOI) varies. Please see <i>Section H.21</i> for DBOI minimums and other relative dimensions. You must also factor in the bottom panel thickness and bottom panel inset option of the drawer box when calculating the drawer box minimum height.</p> <p>Assembled drawer boxes built between the Maximum and Absolute Maximum sizes will be subject to an "Oversized" Drawer Box Assembly Charge, due to special handling requirements. See <i>Section H.1</i> of our current Wholesale Pricing Catalog for upcharges.</p>

Notes continued on next page...

► For PRICING ► See *Section H.3* in our current Wholesale Pricing Catalog.

Technical Notes: Style 100FR - French Dovetail Drawer Boxes...continued

Top Edge Profile Options

1	"TE1" Top Edge	Constructed with the sides 3.0mm shorter than the front and back of the box. On 3/4" [19.1mm] thick material, the sides are 4.0mm shorter than the front and back of the box.
		All edges are eased.
		When ordering, please give the height dimension using the size for the front and back.
2	"TE2" Top Edge	Constructed with the sides 3.0mm shorter than the front and back of the box.
		All edges are square.
		When ordering, please give the height dimension using the size for the front and back.
3	"TE4" Top Edge	Top edges are flush and square on all sides.

► For PRICING ► See Section **H.3** in our current Wholesale Pricing Catalog.

Drawer Box Options

Drawer Box Style 100DW - Doweled (Plywood)

Style 100DW - Doweled Drawer Boxes (Plywood - Veneer Core, MDF Core & Baltic Birch)

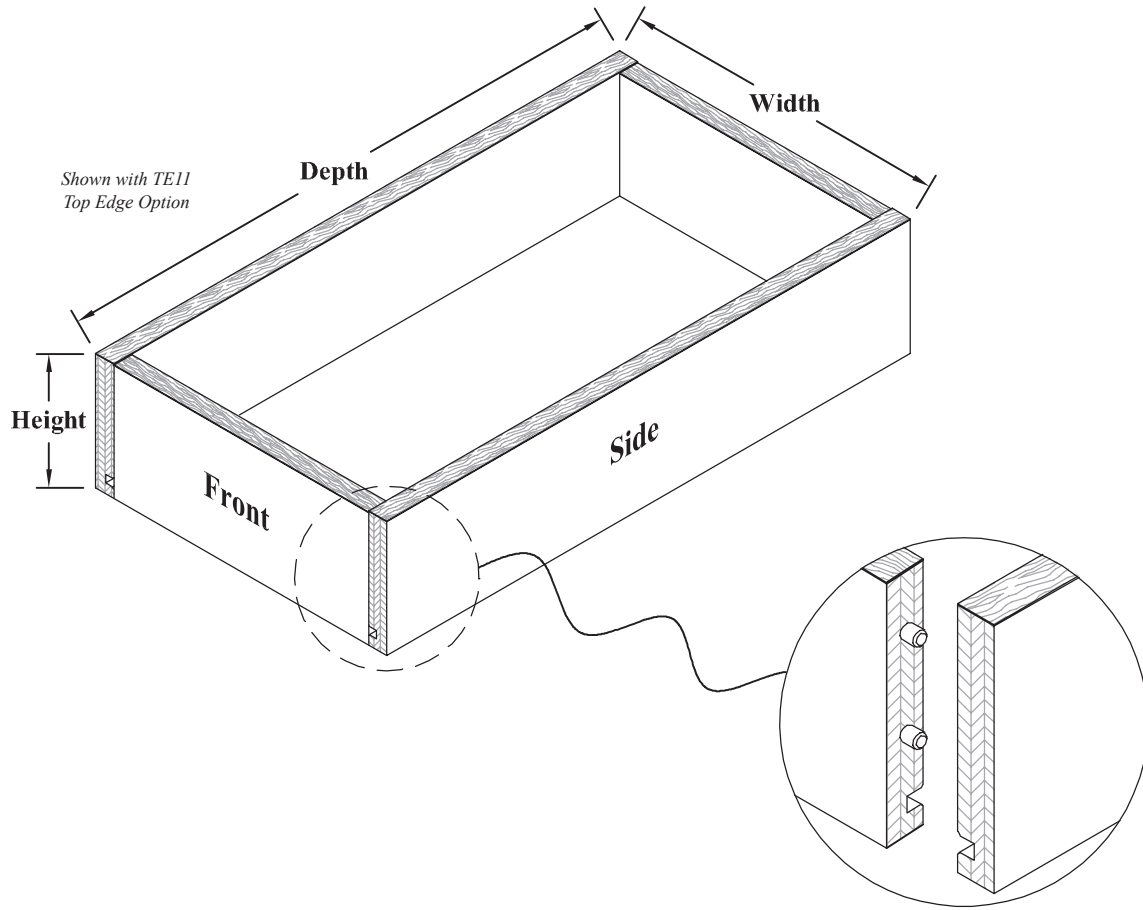

Doweled - Veneer Core Plywood



Doweled - MDF Core Plywood



Doweled - Baltic Birch Plywood



► For PRICING ► See Section H.4 in our current Wholesale Pricing Catalog.

Style 100DW - Doweled (Plywood) Drawer Boxes - Top Edge Options

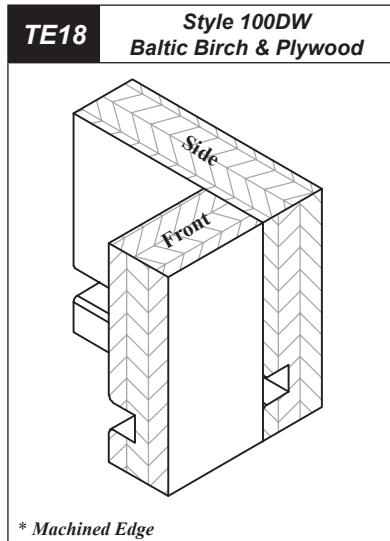
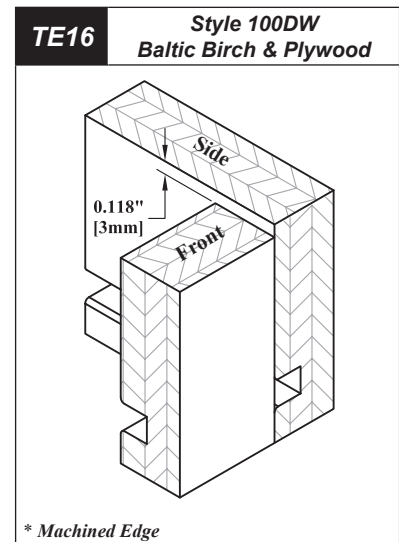
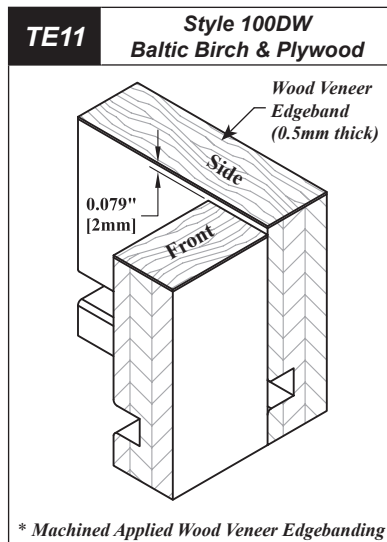
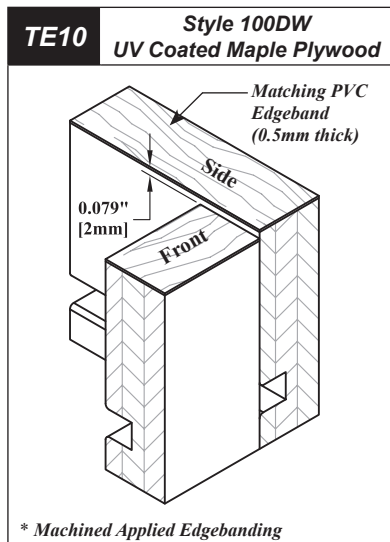

Ordering & Pricing Notes: Style 100DW - Doweled Drawer Boxes (Plywood)

Ordering Guidelines

1	Order Forms	Please use <i>Drawer Box Order Form (E-Z Form #4)</i> .
		Some drawer box options will require the use of the "Advanced Version" of the form.

Pricing

1	Sidewall Material	Please see <i>Section H.4</i> of our current Wholesale Pricing Catalog for pricing front/back/sidewall material and top edge options.
2	Bottom Panel Material	Please see <i>Section H.6</i> of our current Wholesale Pricing Catalog for pricing bottom panel material.

Technical Notes: Style 100DW - Doweled Drawer Boxes (Plywood)

Required Options - Veneer Core & MDF Core - Assembled and RTA (Chapter H)

1	Top Edge Profile	Assembled <i>and/or</i> Ready to Assemble (RTA): Available with TE10, TE11, TE16, TE18. • TE10 only available with UV Coated Maple plywood. UV Coated Maple plywood only available with TE10.
2	Bottom Panel Inset	Assembled <i>and/or</i> Ready to Assemble (RTA): Available with all bottom panel inset options. See <i>Section H.6</i> . • Melamine bottom panels are not available with Bottom Mount or Flush Inset options.

Continued on next page...

► **For PRICING** ► See *Section H.4* in our current Wholesale Pricing Catalog.

Technical Notes: Style 100DW - Doweled Drawer Boxes (Plywood)...continued

Additional Options - Veneer Core & MDF Core - Assembled and RTA (Chapter H)

1	Drawer Slide Notching	Assembled: Available with all drawer slide notching options. See <i>Section H.7</i> .
		Ready to Assemble (RTA): Available with the DBN500 drawer slide notching option. See <i>Section H.7</i> .
2	Shaped Side Patterns	Assembled <i>and/or</i> Ready to Assemble (RTA): Not available with any shaped side patterns.
3	Scoop Fronts	Assembled <i>and/or</i> Ready to Assemble (RTA): Available with all scoop front options. See <i>Section H.9</i> . • Scoop fronts not available with MDF core plywood or UV Coated Maple plywood.
4	Ears	Assembled <i>and/or</i> Ready to Assemble (RTA): Not available with ears.
5	Hanging File Slot	Assembled <i>and/or</i> Ready to Assemble (RTA): Not available with any hanging file slot options.
6	Accented Top Edge	Assembled <i>and/or</i> Ready to Assemble (RTA): Not available with accented top edge.
7	Laser Engraving	Assembled <i>and/or</i> Ready to Assemble (RTA): Not available with laser engraving.
8	Bread Box Slideback Lid	Assembled <i>and/or</i> Ready to Assemble (RTA): Not available with bread box slideback lid.
9	Notched Patterns	Assembled <i>and/or</i> Ready to Assemble (RTA): Not available with any notched patterns.
10	Curved Front Patterns	Assembled <i>and/or</i> Ready to Assemble (RTA): Not available with any curved front patterns.
11	Inside Corner Patterns	Assembled <i>and/or</i> Ready to Assemble (RTA): Not available with any inside corner patterns.
12	Drawer Slide Blocking	Assembled <i>and/or</i> Ready to Assemble (RTA): Not available with any drawer slide blocking for release clip options.
13	No Glue-Up Option	Assembled <i>and/or</i> Ready to Assemble (RTA): Not available with the No Glue-Up Option.

Required Options - Baltic Birch - Assembled and RTA (Chapter H)

1	Top Edge Profile	Assembled <i>and/or</i> Ready to Assemble (RTA): Available with TE11, TE16, TE18.
2	Bottom Panel Inset	Assembled <i>and/or</i> Ready to Assemble (RTA): Available with all bottom panel inset options. See <i>Section H.6</i> .

Additional Options - Baltic Birch - Assembled and RTA (Chapter H)

1	Drawer Slide Notching	Assembled: Available with all drawer slide notching options. See <i>Section H.7</i> .
		Ready to Assemble (RTA): Available with the DBN500 drawer slide notching option. See <i>Section H.7</i> .
2	Shaped Side Patterns	Assembled <i>and/or</i> Ready to Assemble (RTA): Not available with any shaped side patterns.
3	Scoop Fronts	Assembled <i>and/or</i> Ready to Assemble (RTA): Available with all scoop front options. See <i>Section H.9</i> .
4	Ears	Assembled <i>and/or</i> Ready to Assemble (RTA): Not available with ears.
5	Hanging File Slot	Assembled <i>and/or</i> Ready to Assemble (RTA): Not available with any hanging file slot options.
6	Accented Top Edge	Assembled <i>and/or</i> Ready to Assemble (RTA): Not available with accented top edge.
7	Laser Engraving	Assembled <i>and/or</i> Ready to Assemble (RTA): Available with laser engraving.
8	Bread Box Slideback Lid	Assembled <i>and/or</i> Ready to Assemble (RTA): Not available with bread box slideback lid.
9	Notched Patterns	Assembled <i>and/or</i> Ready to Assemble (RTA): Not available with any notched patterns.
10	Curved Front Patterns	Assembled <i>and/or</i> Ready to Assemble (RTA): Not available with any curved front patterns.
11	Inside Corner Patterns	Assembled <i>and/or</i> Ready to Assemble (RTA): Not available with any inside corner patterns.
12	Drawer Slide Blocking	Assembled <i>and/or</i> Ready to Assemble (RTA): Not available with any drawer slide blocking for release clip options.
13	No Glue-Up Option	Assembled <i>and/or</i> Ready to Assemble (RTA): Not available with the No Glue-Up Option.

Finish Options - Assembled and RTA (Chapter R)

1	Natural / Clear Coat (no stain)	Assembled: Plywood Doweled drawer boxes are available unfinished or finished with WalzCraft's <i>water base</i> Natural / Clear Coat (<i>no stain</i>) finish. • WalzCraft has used water base finish on assembled drawer boxes since 2009. • Water base finish is Urea Formaldehyde Free. • No finish is applied to the underside of drawer box. ◦ <i>Underside can be finished upon request, but additional charges will apply.</i>
		Ready to Assemble (RTA): Plywood Doweled drawer boxes are available unfinished or finished with Walzcraft's <i>solvent base</i> Natural / Clear Coat (<i>no stain</i>) finish. UV Coated Maple plywood does not require any additional finishing.
2	Primed Only for Paint	Assembled <i>and/or</i> Ready to Assemble (RTA): Plywood Doweled drawer boxes are not available with a "Primed Only for Paint" finish.
3	SolidTone®	Assembled <i>and/or</i> Ready to Assemble (RTA): Plywood Doweled drawer boxes are not available with a SolidTone® finish.

Continued on next page...

► For PRICING ► See *Section H.4* in our current Wholesale Pricing Catalog.

Drawer Box Style 100DW - Doweled (Plywood)

Drawer Box Options

Technical Notes: Style 100DW - Doweled Drawer Boxes (Plywood)...continued

Hardware Options (Chapter I)

1	Drawer Slide Release Clips	Drawer box style 100DW is available with undermount drawer slide release clips/locking devices installed. Please see <i>Chapter I</i> of the Product Specifications Catalog for restrictions.
---	-----------------------------------	--

Material Options

1	Material	Doweled drawer boxes are available in veneer core plywood (includes UV Coated Maple ply.), MDF core plywood and baltic birch plywood.
2	Budget/Value Grade	WalzCraft has established the grade “ BG ” to indicate a “ Budget /Value Grade ” of material. Budget grade materials include mineral, sap, small glue-ups (n/a with plywood), and other characteristics common in whatever species you order. The wood is structurally sound and a good value if you are able to use them in your project.

Miscellaneous

1	Hot Melt Glue	Hot melt glue is applied to the bottom of all assembled drawer boxes for added strength. This excludes boxes being built without bottom panels, boxes with bottom mount or flush inset bottom panels and boxes with DBN500 drawer slide notching. Please see <i>Section H.8</i> for more information.
---	----------------------	--

Ready to Assemble (RTA)

1	Ready To Assemble	Veneer core and MDF core plywood and baltic birch Doweled drawer boxes are available Ready to Assemble (RTA).
2	Customer Supplied Drawer Box Bottom	When ordering RTA drawer boxes and supplying your own bottom panel, please specify the Bottom Panel Inset Option (see <i>Section H.6</i>) and the width of the Dado Groove based on your bottom panel thickness. Dado Groove Widths: None, .225" [5.7mm], .250" [6.4mm], .450" [11.4mm], .500" [12.7mm].
3	Freight Costs	Ordering drawer boxes Ready to Assemble (RTA) may provide you savings in freight costs.
4	Dowels	When ordering a doweled drawer box RTA , dowels will be included.

Sizes/Dimensions

1	Sidewall Thickness	Standard Plywood: Available in ½" [12.7mm], ⅝" [15.9mm] and ¾" [19.1mm] thicknesses. Baltic Birch Plywood: Available in 12.5mm, 15.2mm, 18.0mm thicknesses.
2	Minimum & Maximum Sizes	Assembled and/or Ready to Assemble (RTA): Width: Minimum = 4¾" [120.7mm]. Maximum = 43" [1092.2mm]. Absolute Maximum = 60" [1524.0mm]. Depth: Minimum = 4¾" [120.7mm]. Maximum = 36" [914.4mm]. Absolute Maximum = 60" [1524.0mm]. Height: Minimum = 1¼" [44.5mm]. Maximum = 14½" [368.3mm]. Absolute Maximum = 30" [762.0mm]. Drawer boxes cannot exceed an absolute maximum <i>depth</i> of 48" [1219.2mm] when bottom panel grain direction is running left to right or a <i>width</i> of 48" [1219.2mm] when bottom panel grain direction is running front to back. The minimum height of a drawer box with a DB Organizer Insert (DBOI) varies. Please see <i>Section H.20</i> for DBOI minimums and other relative dimensions. You must also factor in the bottom panel thickness and bottom panel inset option of the drawer box when calculating the drawer box minimum height. Assembled drawer boxes built between the Maximum and Absolute Maximum sizes will be subject to an “ Oversized ” Drawer Box Assembly Charge, due to special handling requirements. See <i>Section H.1</i> of our current Wholesale Pricing Catalog for upcharges.

Top Edge Options

1	“TE10” Top Edge	Top edge option is constructed with the front and back being 2.0mm shorter than the sides of the box and finished with a matching PVC edgeband 0.5mm thick. When ordering, please give the height dimension using the size for the sides.
2	“TE11” Top Edge	Top edge option is constructed with the front and back being 2.0mm shorter than the sides of the box and finished with a veneer edgeband 0.5mm thick. When ordering, please give the height dimension using the size for the sides.
3	“TE16” Top Edge	Constructed with the front and back being 3.0mm shorter than the sides of the box. All edges are square. When ordering, please give the height dimension using the size for the sides.
4	“TE18” Top Edge	Top edges are flush and square on all sides.

DB Style 100DW - Doweled (Plywood) - END

► For PRICING ► See Section H.4 in our current Wholesale Pricing Catalog.

Drawer Box Options

Drawer Box Style 100DW - Doweled (Melamine)

Style 100DW - Doweled Drawer Boxes (Melamine with Particle Board Core)

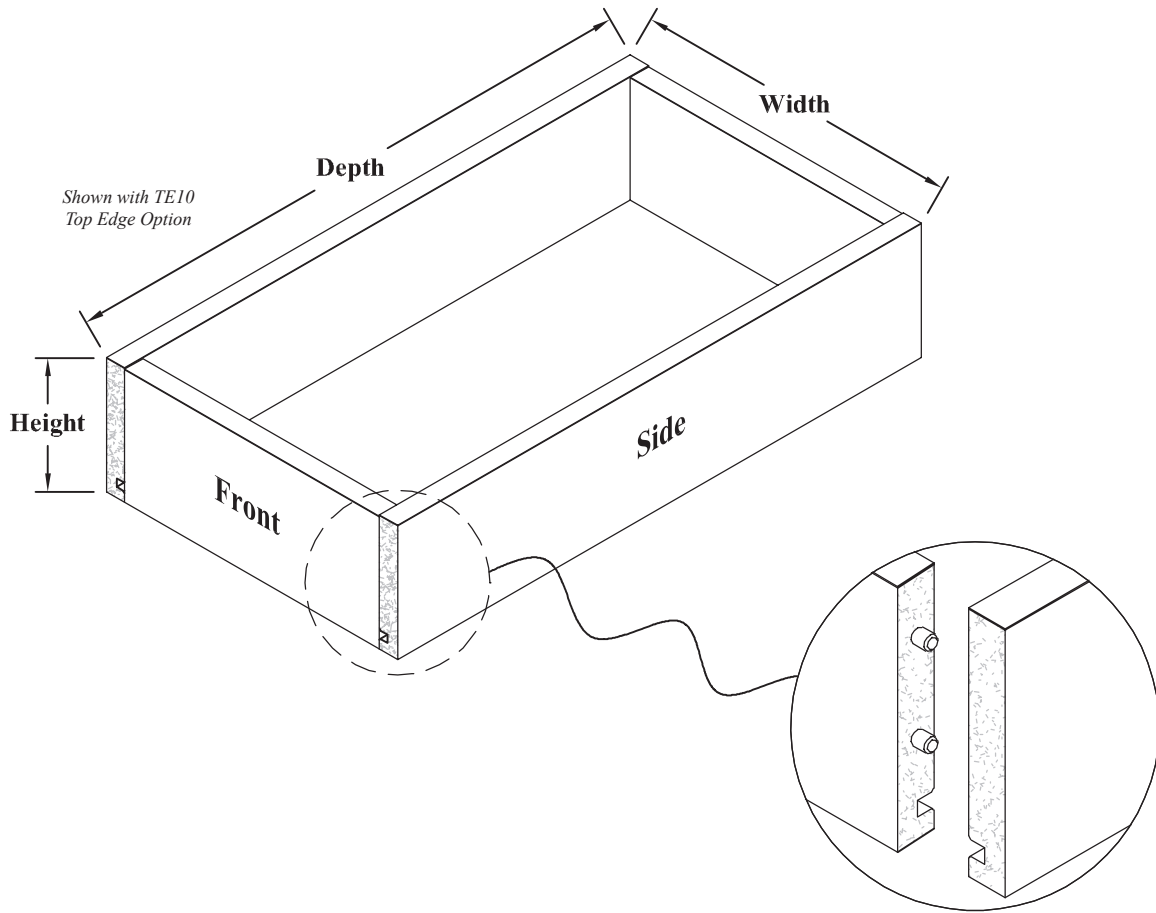

Doweled - White Melamine



Doweled - Almond Melamine



Doweled - Maple Melamine



► For PRICING ► See Section H.5 in our current Wholesale Pricing Catalog.

Style 100DW - Doweled (Melamine) Drawer Boxes - Top Edge Options

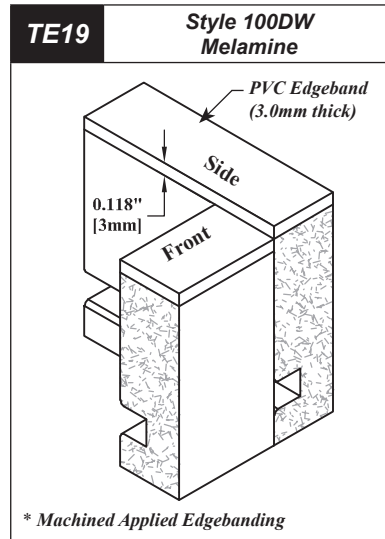
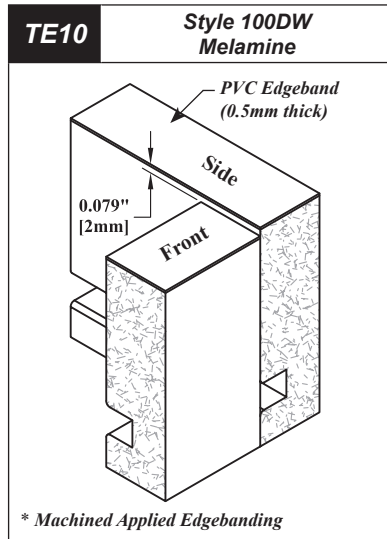

* Machined Applied Edgebanding

* Machined Applied Edgebanding

Ordering & Pricing Notes: Style 100DW - Doweled Drawer Boxes (Melamine)

Ordering Guidelines

1	Order Forms	Please use <i>Melamine Drawer Box Order Form (E•Z Form #4.3)</i> .
Pricing		
1	Sidewall Material	Please see <i>Section H.5</i> of our current Wholesale Pricing Catalog for pricing front/back/sidewall material and top edge options.
2	Bottom Panel Material	Please see ¼" and ½" thick melamine options from <i>Section H.6</i> of our current Wholesale Pricing Catalog for pricing bottom panel material.

Technical Notes: Style 100DW - Doweled Drawer Boxes (Melamine)

Required Options - Melamine - Assembled and RTA (Chapter H)

1	Top Edge Profile	Assembled and/or Ready to Assemble (RTA): Available with TE10, TE19.
2	Bottom Panel Inset	Assembled and/or Ready to Assemble (RTA): Available with all bottom panel inset options <i>except</i> Flush Inset. See <i>Section H.6</i> . • Melamine bottom panels are not available with Bottom Mount or Flush Inset options.

Additional Options - Melamine - Assembled and RTA (Chapter H)

1	Drawer Slide Notching	Assembled: Available with all drawer slide notching options. See <i>Section H.7</i> . Ready to Assemble (RTA): Available with the DBN500 drawer slide notching option. See <i>Section H.7</i> .
2	Shaped Side Patterns	Assembled and/or Ready to Assemble (RTA): Not available with any shaped side patterns.
3	Scoop Fronts	Assembled and/or Ready to Assemble (RTA): Not available with any scoop front options.
4	Ears	Assembled and/or Ready to Assemble (RTA): Not available with ears.
5	Hanging File Slot	Assembled and/or Ready to Assemble (RTA): Not available with any hanging file slot options.
6	Accented Top Edge	Assembled and/or Ready to Assemble (RTA): Not available with accented top edge.
7	Laser Engraving	Assembled and/or Ready to Assemble (RTA): Not available with laser engraving.
8	Bread Box Slideback Lid	Assembled and/or Ready to Assemble (RTA): Not available with bread box slideback lid.
9	Notched Patterns	Assembled and/or Ready to Assemble (RTA): Not available with any notched patterns.
10	Curved Front Patterns	Assembled and/or Ready to Assemble (RTA): Not available with any curved front patterns.
11	Inside Corner Patterns	Assembled and/or Ready to Assemble (RTA): Not available with any inside corner patterns.
12	Drawer Slide Blocking	Assembled and/or Ready to Assemble (RTA): Not available with any drawer slide blocking for release clip options.
13	No Glue-Up Option	Assembled and Ready to Assemble (RTA): Not available with the No Glue-Up Option.

Continued on next page...

► For PRICING ► See *Section H.5* in our current Wholesale Pricing Catalog.

Drawer Box Options

Drawer Box Style 100DW - Doweled (Melamine)

Technical Notes: Style 100DW - Doweled Drawer Boxes (Melamine)...continued

Finish Options - Assembled and RTA (Chapter R)

1	Finish	Assembled <i>and/or</i> Ready to Assemble (RTA): Melamine Doweled drawer boxes are not available with any finish.
---	--------	---

Hardware Options (Chapter I)

1	Drawer Slide Release Clips	Drawer box style 100DW is available with undermount drawer slide release clips / locking devices installed. Please see <i>Chapter I</i> of the Product Specifications Catalog for restrictions.
---	----------------------------	--

Material Options

1	Material	Doweled melamine drawer boxes are available in white, almond or a maple wood grain pattern.
---	----------	---

Miscellaneous

1	Hot Melt Glue	Hot melt glue is applied to the bottom of all assembled drawer boxes for added strength. This excludes boxes being built without bottom panels, boxes with the bottom mount panel inset option and boxes with DBN500 drawer slide notching. Please see <i>Section H.7</i> for more information.
2	Drawer Box Dowels	All doweled drawer boxes with ½" [12.7mm], ⅝" [15.9mm] or ¾" [19.1mm] sidewall thickness use 6.0mm diameter x 13.0mm long dowels.

Ready to Assemble (RTA)

1	Ready To Assemble	Doweled melamine drawer boxes are available Ready to Assemble (RTA).
2	Customer Supplied Drawer Box Bottom	When ordering RTA drawer boxes and supplying your own bottom panel, please specify the Bottom Panel Inset Option (see <i>Section H.7</i>) and the width of the Dado Groove based on your bottom panel thickness. Dado Groove Widths: None, .225" [5.7mm], .250" [6.4mm], .450" [11.4mm], .500" [12.7mm].
3	Freight Costs	Ordering drawer boxes Ready to Assemble (RTA) may provide you savings in freight costs.
4	Dowels	When ordering a doweled drawer box Ready to Assemble (RTA), dowels will be included.

Sizes/Dimensions

1	Sidewall Thickness	Available in ½", ⅝" and ¾" nominal thicknesses. See Melamine Sheet Stock in <i>Section V.4</i> for exact melamine thicknesses with tolerances.
2	Minimum & Maximum Sizes	<p>Assembled and Ready to Assemble (RTA): Width: Minimum = 4¾" [120.7mm]. Maximum = 43" [1092.2mm]. Absolute Maximum = 60" [1524.0mm]. Depth: Minimum = 4¾" [120.7mm]. Maximum = 36" [914.4mm]. Absolute Maximum = 60" [1524.0mm]. Height: Minimum = 1¾" [44.5mm]. Maximum = 14½" [368.3mm]. Absolute Maximum = 30" [762.0mm].</p> <p>Drawer boxes cannot exceed an absolute maximum <i>depth</i> of 48" [1219.2mm] when bottom panel grain direction is running left to right or a <i>width</i> of 48" [1219.2mm] when bottom panel grain direction is running front to back.</p> <p>The minimum height of a drawer box with a DB Organizer Insert (DBOI) varies. Please see <i>Section H.20</i> for DBOI minimums and other relative dimensions. You must also factor in the bottom panel thickness and bottom panel inset option of the drawer box when calculating the drawer box minimum height.</p> <p>Assembled drawer boxes built between the Maximum and Absolute Maximum sizes will be subject to an "Oversized" Drawer Box Assembly Charge, due to special handling requirements. See <i>Section H.1</i> of our current Wholesale Pricing Catalog for upcharges.</p>

Top Edge Options

1	"TE10" Top Edge	<p>Top edge option is constructed with the front and back being 2.0mm shorter than the sides of the box and finished with a PVC edgeband 0.5mm thick.</p> <p>When ordering, please give the height dimension using the size for the sides.</p>
2	"TE19" Top Edge	<p>Top edge option is constructed with the front and back being 3.0mm shorter than the sides of the box and finished with a PVC edgeband 3.0mm thick.</p> <p>When ordering, please give the height dimension using the size for the sides.</p>

DB Style 100DW - Doweled (Melamine) - END

► For PRICING ► See *Section H.5* in our current Wholesale Pricing Catalog.

Drawer Box Options

Drawer Box Bottom Panels

Drawer Box Bottom Panel Inset Options

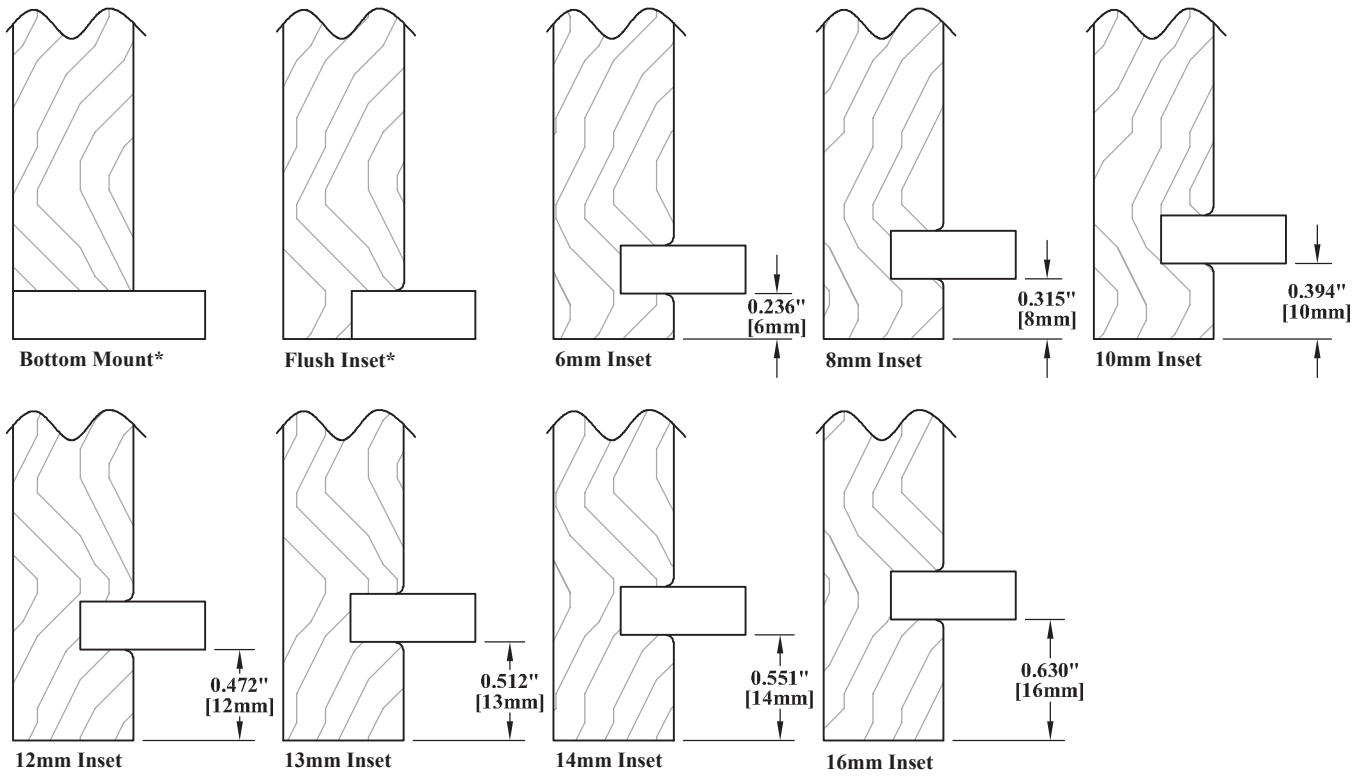

*Not available with melamine bottom panels

Ordering & Pricing Notes: Drawer Box Bottom Panels

Ordering Guidelines

1	Order Forms	Applicable drawer box order forms will include spaces to indicate your chosen option.
Pricing		
1	Pricing	Please see <i>Section H.6</i> of our current Wholesale Pricing Catalog.

Technical Notes: Drawer Box Bottom Panels

Required Options (Chapter H)

1	Drawer Box Styles	Please see individual drawer box <i>Sections H.1</i> through <i>H.5</i> for compatible drawer box styles.
2	Top Edge Profile Options	See chosen drawer box style for available top edge profile options.
3	Veneer Bottom Panel Grain Direction	Random = The grain direction of the plywood bottoms may vary within the order. The bottom panel material is optimized for greater yield, resulting in minimal waste.
		Left to Right = All drawer box bottoms within the order will have a Left to Right grain direction. Maximum drawer box depth with bottom panel grain direction running from left to right is 48" [1219.2mm].
		Front to Back = All drawer box bottoms within the order will have a Front to Back grain direction. Maximum drawer box width with bottom panel grain direction running from front to back is 48" [1219.2mm].

Continued on next page...

► For PRICING ► See *Section H.6* in our current Wholesale Pricing Catalog.

Technical Notes: Drawer Box Bottom Panels...continued

Additional Options (Chapter H)

1	Drawer Box Options	<p>Compatible with the following drawer box options:</p> <ul style="list-style-type: none"> • Drawer Slide Notching (<i>Section H.7</i>) • Shaped Side Patterns (<i>Section H.8</i>) • Scoop Fronts (<i>Section H.9</i>) • Ears (<i>Section H.10</i>) • Hanging File Slot (<i>Section H.11</i>) • Accented Top Edge (<i>Section H.12</i>) • Laser Engraving (<i>Section H.13</i>) • Bread Box Slideback Lid (<i>Section H.14</i>) • Notched Patterns (<i>Section H.15</i>) • Curved Front Patterns (<i>Section H.16</i>) • Inside Corner Patterns (<i>Section H.17</i>) • Drawer Slide Blocking (<i>Section H.18</i>) • No Glue-Up Option (<i>Section H.19</i>) <p>See individual drawer box option <i>Sections H.7</i> through <i>H.19</i> for more information, as restrictions may apply.</p>
----------	---------------------------	---

H

Finish Options (Chapter R)

1	Finish Options	See individual drawer box styles for available finish options.
2	Melamine Bottom Panels	Melamine bottom panels are not available with any finish.
3	UV Coated Bottom Panels	UV Coated Maple bottom panels are not available with any finish.

Material Options

1	Budget/Value Grade	WalzCraft has established the grade “ BG ” to indicate a “ Budget / Value Grade ” of material. Budget grade materials include mineral, sap, small glue-ups (n/a with plywood bottoms), and other characteristics common in whatever species you order. The wood is structurally sound and a good value if you are able to use them in your project.
----------	---------------------------	---

Ready to Assemble (RTA)

1	Drawer Box Styles	Please see individual drawer box <i>Sections H.1</i> through <i>H.5</i> for drawer box styles that are compatible with Ready to Assemble (RTA) construction.
2	Customer Supplied Drawer Box Bottom	<p>When ordering Ready to Assemble (RTA) drawer boxes and supplying your own bottom panel, please specify the Bottom Panel Inset Option (see <i>previous page</i>) and the width of the Dado Groove based on your bottom panel thickness.</p> <p>Dado Groove Widths: None, .225" [5.7mm], .250" [6.4mm], .450" [11.4mm], .500" [12.7mm].</p>

Drawer Box Bottom Panels - END

► **For PRICING** ► See *Section H.6* in our current Wholesale Pricing Catalog.

NHH1 - Notch and Hook Hole

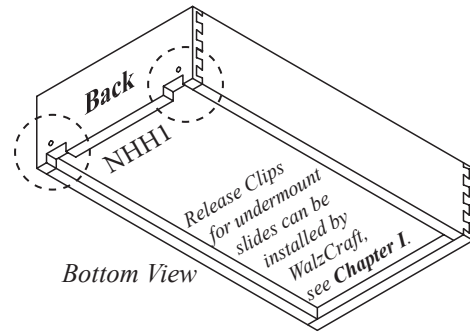
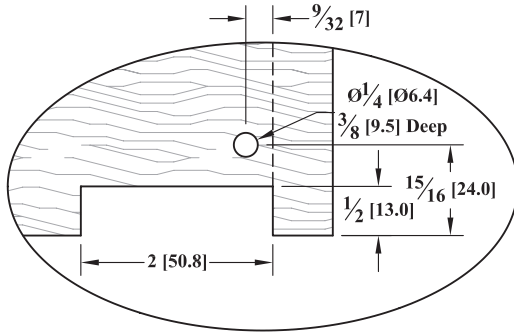

Standard Notch and Hook Hole set up for the NHH1.

Ordering & Pricing Notes: NHH1 - Notch & Hook Hole

Ordering Guidelines

1	Order Forms	Please use Drawer Box Order Form (E•Z Form #4) . • The drawer box order form will include spaces to indicate your chosen option.
----------	--------------------	--

Pricing

1	Pricing	Please see Section H.7 of our current Wholesale Pricing Catalog .
----------	----------------	---

Technical Notes: NHH1 - Notch & Hook Hole

Required Options (Chapter H)

1	Drawer Box Styles	Please see individual drawer box Sections H.1 through H.5 for compatible drawer box styles.
2	Top Edge Profile Options	See chosen drawer box style for available top edge profile options.
3	Bottom Panel Inset Options	The NHH1 option is only available when using a 13.0mm bottom panel inset.

Additional Options (Chapter H)

1	Drawer Box Options	<p>Compatible with the following drawer box options:</p> <ul style="list-style-type: none"> • Shaped Side Patterns (Section H.8) • Scoop Fronts (Section H.9) • Hanging File Slot (Section H.11) • Accented Top Edge (Section H.12) • Laser Engraving (Section H.13) • Bread Box Slideback Lid (Section H.14) • Notched Patterns (Section H.15) • Curved Front Patterns (Section H.16) • Inside Corner Patterns (Section H.17) • Drawer Slide Blocking (Section H.18) <p>See individual drawer box option Sections H.8 through H.18 for more information, as restrictions may apply.</p>
----------	---------------------------	--

Hardware Options (Chapter I)

1	Drawer Glide Compatibility	Compatible with many Salice, Blum, Hettich, Grass and Mepla drawer glide systems, including: Futura A7555, A7557, Tandem 552H, 552F, Tandem Plus 562H, 568H, 568, 568F, 568A, Tandem plus Blumotion 563H, Quadro IW20, IW21, Dynapro, and Elite Plus Series. For models not listed, please consult your drawer glide specifications for drawer back preparation requirements.
----------	-----------------------------------	--

Notes continued on next page...

► **For PRICING** ► See **Section H.7** in our current **Wholesale Pricing Catalog**.

Drawer Slide Notching

Drawer Box Options

Technical Notes: NHH1 - Notch & Hook Hole...continued

Miscellaneous

1	Application	Applied to the back side of the drawer box only.
---	--------------------	--

Ready to Assemble (RTA)

1	Ready to Assemble (RTA)	Drawer boxes with the NHH1 drawer slide notching option are not available Ready to Assemble (RTA).
---	--------------------------------	--

Sizes / Dimensions

1	Sidewall Thicknesses	Available with sidewall thicknesses of ½" [12.7mm], ⅜" [15.9mm] and ¼" [19.1mm].
2	Minimum Drawer Box Depth	The minimum drawer box depth will be 9" [228.6mm] when applying the NHH1 notching option.
3	Notch Width	The NHH1 will accommodate drawer slides requiring notching up to 2" [50.8mm] wide. There is no minimum width required between notches.

H

► For PRICING ► See Section **H.7** in our current Wholesale Pricing Catalog.

Drawer Box Options

Drawer Slide Notching

Drawer Slide Notching Options

DBN100

Drawer Box Notching

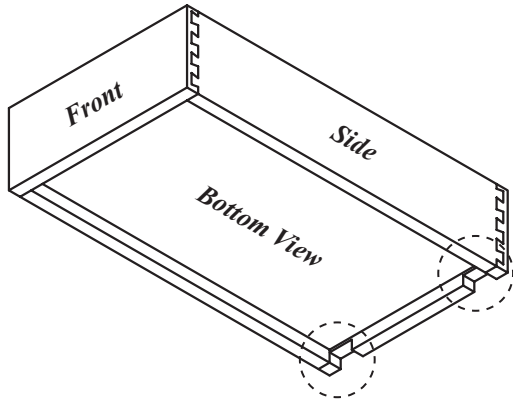

DBN200

Drawer Box Notching

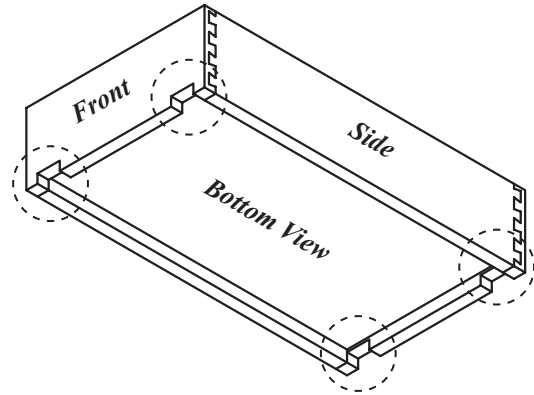

DBN300

Drawer Box Notching

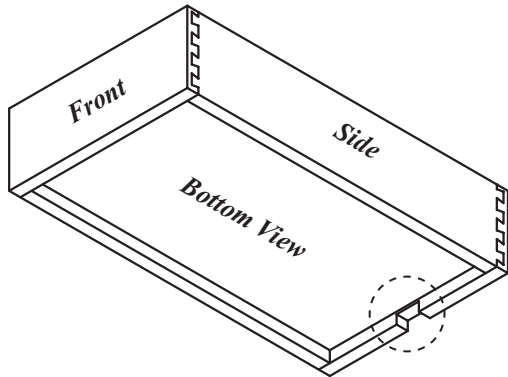

DBN400

Drawer Box Notching

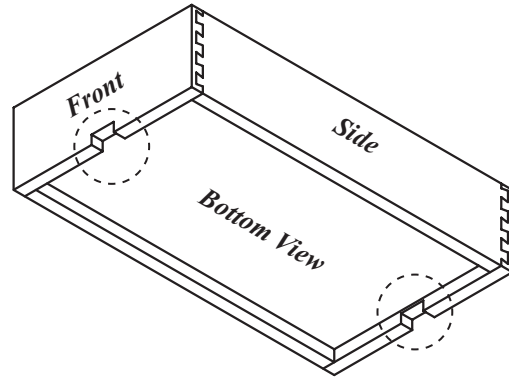

DBN500

Drawer Box Notching

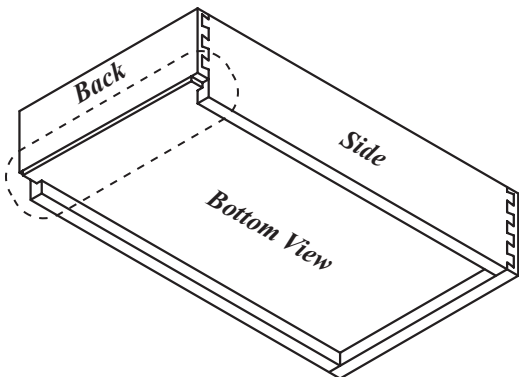

► For PRICING ► See Section H.7 in our current Wholesale Pricing Catalog.

H.7.3
V18.2



WalzCraft.com



(Phone) 1-800-237-1326

6:00AM - 5:30PM CST

(24 Hour Fax) 1-608-781-3667

Hot Melt / Glue Locations on Drawer Boxes

No Notch

Hot Melt / Glue Pattern Options

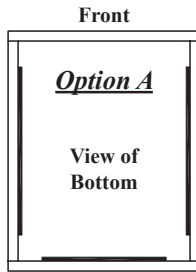

Back

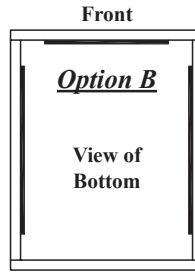

Back

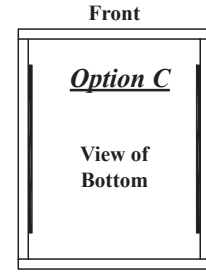

Back

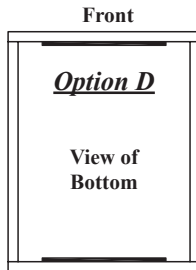

Back

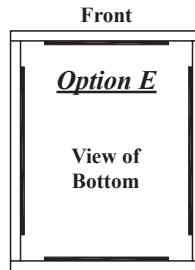

Back

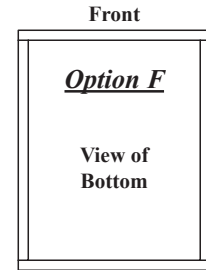

Back

**** Option A will be WalzCraft's standard unless specified otherwise. See Miscellaneous Notes for more information. ****

NHH1 / DBN100 Hot Melt / Glue Pattern

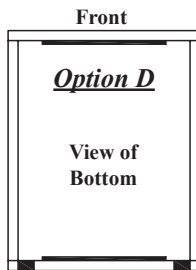

Back

**** Only available with Option D. ****

DBN200 Hot Melt / Glue Pattern

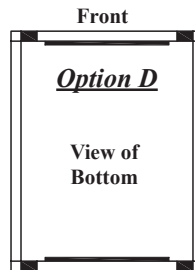

Back

**** Only available with Option D. ****

DBN300 Hot Melt / Glue Pattern

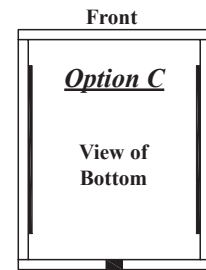

Back

**** Only available with Option C. ****

DBN400 Hot Melt / Glue Pattern

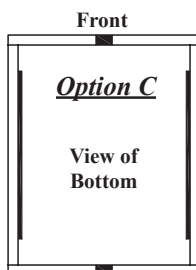

Back

**** Only available with Option C. ****

DBN500 Hot Melt / Glue - NONE

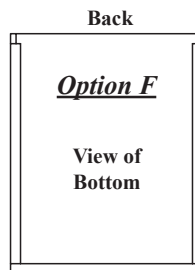

Front

**** Only available with Option F. ****

Key

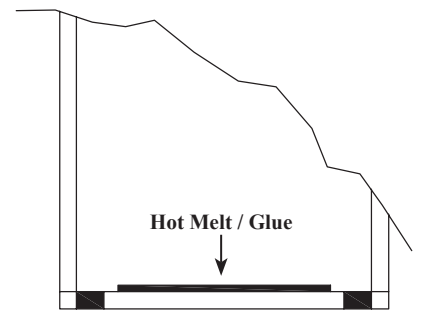

► For PRICING ► See Section H.7 in our current Wholesale Pricing Catalog.

Drawer Box Options

Drawer Slide Notching

Ordering & Pricing Notes: Drawer Slide Notching

Ordering Guidelines

1	Order Forms	Please use Drawer Box Order Form (E•Z Form #4) . • The drawer box order form will include spaces to indicate your chosen option.
Pricing		
1	Pricing	Please see Section H.7 of our current Wholesale Pricing Catalog .

Technical Notes: Drawer Slide Notching

Required Options (Chapter H)

1	Drawer Box Styles	Please see individual drawer box Sections H.1 through H.5 for compatible drawer box styles.
2	Top Edge Profile Options	See chosen drawer box style for available top edge profile options.
3	Bottom Panel Inset Options	All drawer box notching options are only available when using a 13.0mm bottom panel inset except DBN500 (Section H.6) .

Additional Options (Chapter H)

1	Drawer Box Options	<p>Compatible with the following drawer box options:</p> <ul style="list-style-type: none"> • Shaped Side Patterns (Section H.8) • Scoop Fronts (Section H.9) • Hanging File Slot (Section H.11) • Accented Top Edge (Section H.12) • Laser Engraving (Section H.13) • Bread Box Slideback Lid (Section H.14) • Notched Patterns (Section H.15) • Curved Fronts (Section H.16) • Inside Corner Patterns (Section H.17) <p>See individual drawer box option Sections H.7 through H.18 for more information, as restrictions may apply.</p>
---	--------------------	---

Miscellaneous

1	Hot Melt / Glue Pattern	<p>Hot melt glue is applied to the bottom of all assembled drawer boxes for added strength. This excludes boxes being built without bottom panels, boxes with bottom mount or flush inset bottom panels and boxes with DBN500 drawer slide notching.</p> <p>No Notching: When no notching is present, WalzCraft's standard will be to apply hot melt/glue where the bottom panel meets the left side, right side and back (Option A).</p> <ul style="list-style-type: none"> • Hot Melt/Glue is not applied at the front and is not applied all the way into the corners. • If required, you can also specify custom placements: <ul style="list-style-type: none"> ◦ Option B: Left side, right side and front. ◦ Option C: Left side and right side. ◦ Option D: Front and back. ◦ Option E: Left side, right side, front and back. ◦ Option F: No hot melt/glue. • Please indicate custom placement in the Special Instructions column on your order form. <p>DBN100 & DBN200: Only available with Option D. Hot Melt/Glue is applied where the bottom panel meets the front and back.</p> <ul style="list-style-type: none"> • Hot Melt/Glue is not applied all the way to the notch or into the corners. <p>DBN300 & DBN400: Only available with Option C. Hot Melt/Glue is applied where the bottom panel meets the left side & right side.</p> <ul style="list-style-type: none"> • Hot Melt/Glue is not applied all the way to the corners. <p>DBN500: Only available with Option F. Hot Melt/Glue is not applied when using this removable bottom panel application.</p> <ul style="list-style-type: none"> • This notching option will allow you to insert your own custom drawer box bottom material.
---	-------------------------	---

Notes continued on next page...

► For PRICING ► See Section H.7 in our current Wholesale Pricing Catalog.



Technical Notes: Drawer Slide Notching...continued

Ready to Assemble (RTA)

1	Ready To Assemble	DBN500 is the only notching option available with Ready to Assemble (RTA) drawer boxes. Must have a bottom panel inset option other than Flush Inset .
----------	--------------------------	--

Sizes / Dimensions

1	Minimum Drawer Box Depth	The minimum drawer box depth will be 9" [228.6mm] when applying the DBN100, DBN200, DBN300, DBN400 or DBN500 notching options.
2	Notch Width	Specify the notch width in 1/4" [6.4mm] increments. <ul style="list-style-type: none"> • No notch width is required for DBN500, as this notch runs the full width of the drawer box.

► **For PRICING** ► See Section **H.7** in our current Wholesale Pricing Catalog.

Drawer Box Options

Shaped Side Patterns

Drawer Box Side Patterns - DBSP100, DBSP600

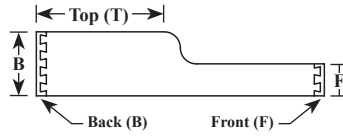
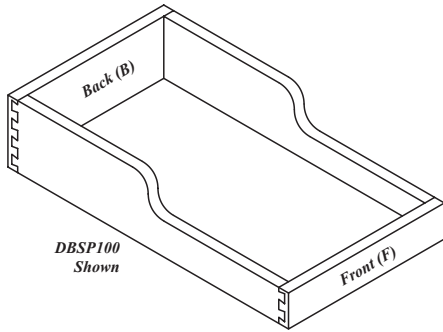

DBSP100

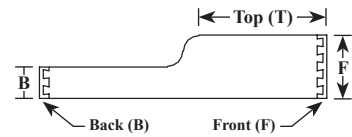

DBSP600

H

Drawer Box Side Patterns - DBSP200, DBSP500

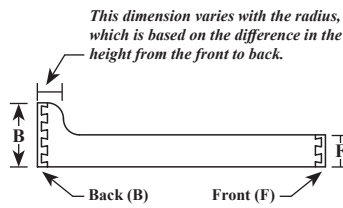
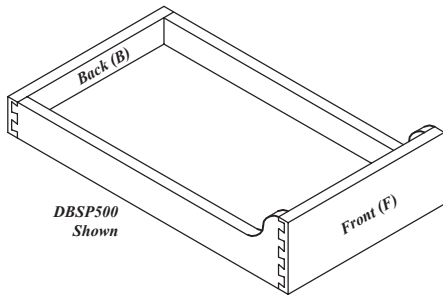

DBSP200

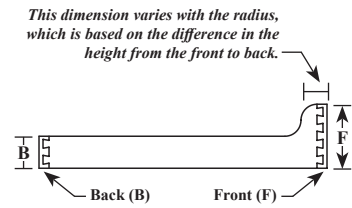

DBSP500

Drawer Box Side Patterns - DBSP700, DBSP800

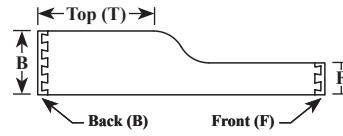
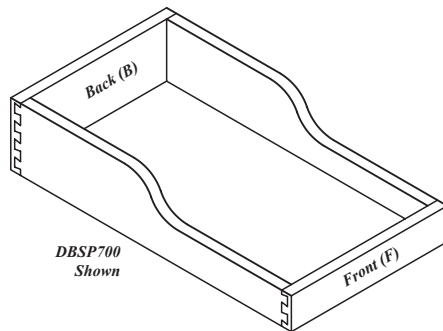

DBSP700

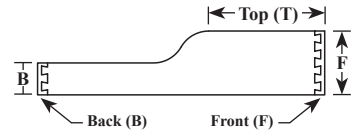

DBSP800

Drawer Box Side Patterns - DBSP300, DBSP900

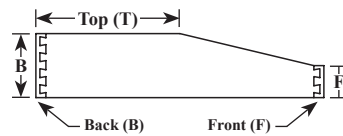
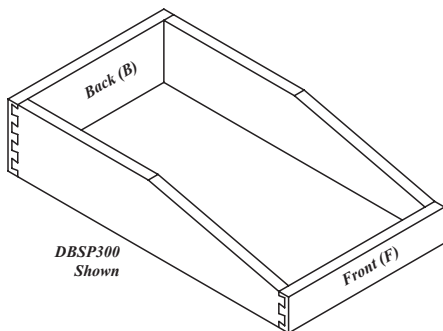

DBSP300

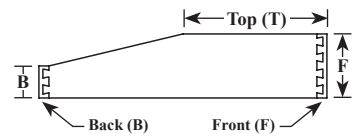

DBSP900

► For PRICING ► See Section H.8 in our current Wholesale Pricing Catalog.

Shaped Side Patterns

Drawer Box Options

Drawer Box Side Patterns - DBSP400, DBSP1000

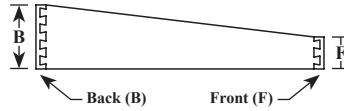
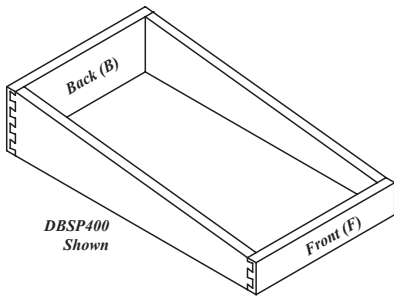

DBSP400

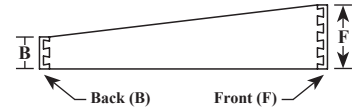

DBSP1000

Ordering & Pricing Notes: Shaped Side Patterns for Drawer Boxes

Ordering Guidelines

1	Order Forms	<p>Please use “<i>Advanced Version</i>” of the <i>Drawer Box Order Form (E•Z Form #4)</i>.</p> <ul style="list-style-type: none"> The drawer box order form will include spaces to indicate your chosen option.
2	Ordering Information	<p>DBSP100, 300, 600, 700, 800, 900 - Please specify the following:</p> <ul style="list-style-type: none"> Overall width and depth of box. Height of box at both the front (F) and back (B). Flat dimension at top (T) of box. See drawings on previous page. <p>DBSP200, 400, 500, 1000 - Please specify the following:</p> <ul style="list-style-type: none"> Overall width and depth of box. Height of box at both the front (F) and back (B). See drawings on previous page.

Pricing

1	Pricing	Please see <i>Section H.8</i> of our current Wholesale Pricing Catalog .
----------	----------------	---

Technical Notes: Shaped Side Patterns for Drawer Boxes

Required Options (Chapter H)

1	Drawer Box Styles	Please see individual drawer box <i>Sections H.1</i> through <i>H.5</i> for compatible drawer box styles.
2	Top Edge Profile Options	<p>See chosen drawer box style for available top edge profile options.</p> <ul style="list-style-type: none"> Assembled & Ready to Assemble (RTA) drawer boxes with shaped side patterns are not available with TE5 or TE14. In cases where the TE Option is “hand routed” on both the face and the backside, you will also find that the shaped side pattern is routed on both the face and the backside (ie: TE3).
3	Bottom Panel Inset Options	Assembled & Ready to Assemble (RTA) drawer boxes with shaped side patterns are available with all bottom panel inset options (<i>Section H.7</i>).

Additional Options (Chapter H)

2	Drawer Box Options	<p>Compatible with the following drawer box options:</p> <ul style="list-style-type: none"> Drawer Slide Notching (<i>Section H.7</i>) Scoop Fronts (<i>Section H.9</i>) Ears (<i>Section H.10</i>) Laser Engraving (<i>Section H.13</i>) Notched Patterns (<i>Section H.15</i>) <p>See individual drawer box option <i>Sections H.7</i> through <i>H.18</i> for more information, as restrictions may apply.</p>
----------	---------------------------	--

Ready to Assemble (RTA)

1	Ready to Assemble (RTA)	Please see individual drawer box <i>Sections H.1</i> through <i>H.5</i> for drawer box styles that are compatible with Ready to Assemble (RTA) construction.
----------	--------------------------------	--

Sizes / Dimensions

1	Height	Minimum height at the shortest is 1¾" [44.5mm].
2	Radii of Side Patterns	<p>DBSP100, 200, 500, 600: Radii on side patterns will be equal to the difference between the front and back height divided by 2.</p> <p>DBSP700, 800: Radii on side patterns will be equal to the difference between the front and back height.</p>

► For PRICING ► See *Section H.8* in our current Wholesale Pricing Catalog.

Scoop Front Options

SC100

Drawer Box Scoop Option

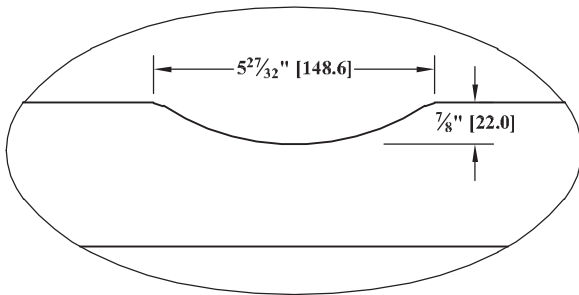
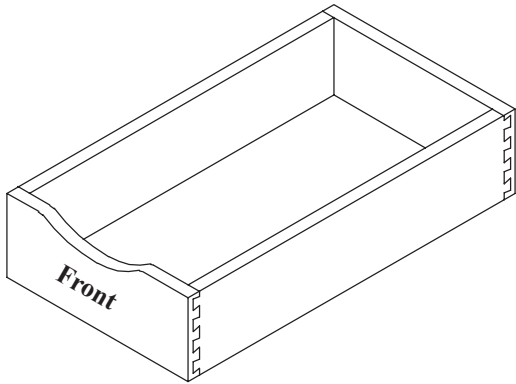

SC200

Drawer Box Scoop Option

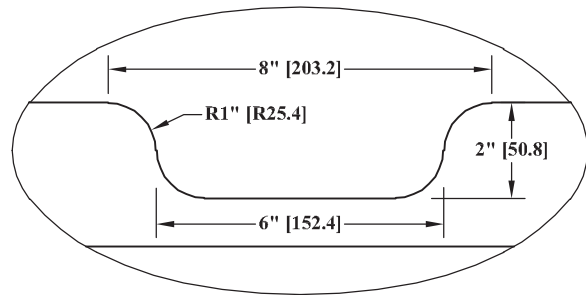
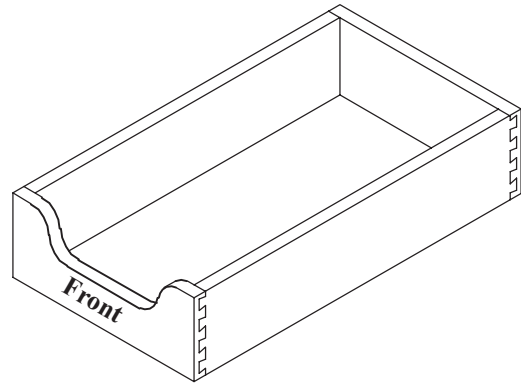

Ordering & Pricing Notes: Scoop Fronts

Ordering Guidelines

1	Order Forms	Please use Drawer Box Order Form (E-Z Form #4) . • The drawer box order form will include spaces to indicate your chosen option.
----------	--------------------	--

Pricing

1	Pricing	Please see Section H.9 of our current Wholesale Pricing Catalog .
----------	----------------	---

Technical Notes: Scoop Fronts

Required Options (Chapter H)

1	Drawer Box Styles	Please see individual drawer box Sections H.1 through H.5 for compatible drawer box styles.
2	Top Edge Profile Options	See chosen drawer box style for available top edge profile options. • Assembled & Ready to Assemble (RTA) drawer boxes with scoop fronts are not available with TE5 , TE11 or TE14 . • In cases where the TE Option is "hand routed" on both the face and the backside, you will also find that the scoop option is routed on both the face and the backside (ie: TE3).
3	Bottom Panel Inset Options	Assembled & Ready to Assemble (RTA) drawer boxes with scoop fronts are available with all bottom panel inset options (Section H.6).

Notes continued on next page...

► **For PRICING** ► See **Section H.9** in our current Wholesale Pricing Catalog.

Technical Notes: Scoop Fronts...continued

Additional Options (Chapter H)

1	Drawer Box Options	<p>Compatible with the following drawer box options:</p> <ul style="list-style-type: none"> • Drawer Slide Notching (<i>Section H.7</i>) • Shaped Side Patterns (<i>Section H.8</i>) • Ears (<i>Section H.10</i>) • Laser Engraving (<i>Section H.13</i>) • Notched Patterns (<i>Section H.15</i>) • Curved Front Patterns (<i>Section H.16</i>) • Drawer Slide Blocking (<i>Section H.18</i>) <p>See individual drawer box option <i>Sections H.7</i> through <i>H.18</i> for more information, as restrictions may apply.</p>
----------	---------------------------	--

Ready to Assemble (RTA)

1	Ready to Assemble (RTA)	Please see individual drawer box <i>Sections H.1</i> through <i>H.5</i> for drawer box styles that are compatible with Ready to Assemble (RTA) construction.
----------	--------------------------------	--

Sizes / Dimensions

1	Scoop Dimensions	<p>Drawer Box Scoop Option SC100 is 5 ⁷/₁₆"W x 7/8"H [148.6mm x 22.2mm].</p> <p>Drawer Box Scoop Option SC200 is 8"W x 2"H [203.2mm x 50.8mm].</p>
2	Minimum Box Size	<p>SC100: Minimum drawer box width is 7" [177.8mm]. Minimum drawer box height is 1 ³/₈" [34.9mm] + bottom panel thickness + bottom panel inset distance.</p> <p>SC200: Minimum drawer box width is 10" [254.0mm]. Minimum drawer box height is 2 ¹/₂" [63.5mm] + bottom panel thickness + bottom panel inset distance.</p>

► For PRICING ► See Section **H.9** in our current Wholesale Pricing Catalog.

Drawer Box “Ear” Option

Drawer Box “Ears” are applied to the front of the drawer box. Often used with pullout style drawer boxes, “ears” can help conceal side mounted hardware.

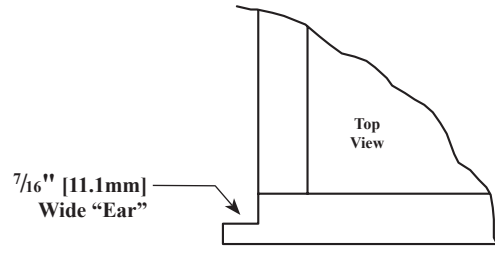

Style 100HB - Half Blind Dovetail Drawer Box with Ears - Top Edge Options

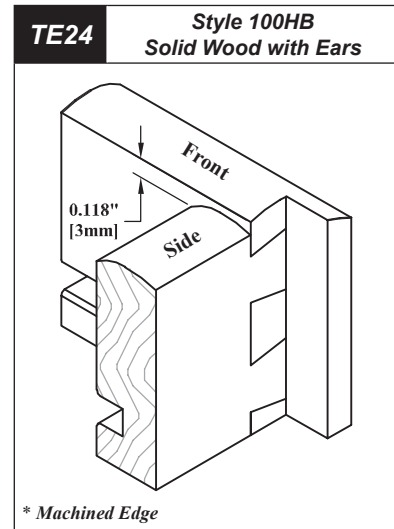
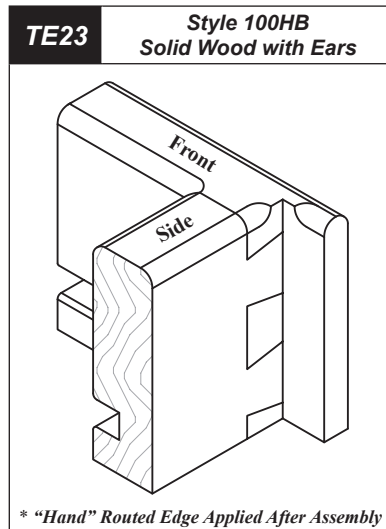
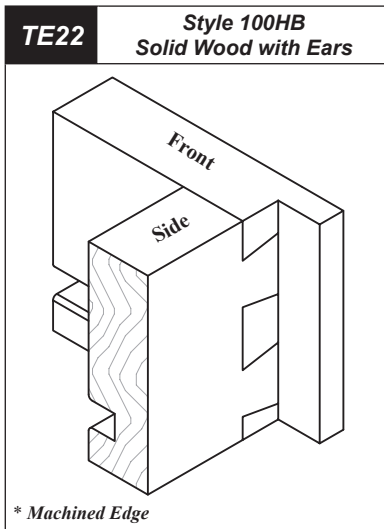

Ordering & Pricing Notes: Drawer Box “Ear”

Ordering Guidelines

1	Order Forms	Please use <i>Drawer Box Order Form (E•Z Form #4)</i> . • The drawer box order form will include spaces to indicate your chosen option.
Pricing		
1	Pricing	Please see <i>Section H.10</i> of our current Wholesale Pricing Catalog .

Technical Notes: Drawer Box “Ear”

Required Options (Chapter H)

1	Drawer Box Styles	Please see individual drawer box <i>Sections H.1</i> through <i>H.5</i> for compatible drawer box styles.
2	Top Edge Profile Options	Assembled: Solid wood Half Blind Dovetail drawer boxes assembled with ears are only available with TE22, TE23 or TE24 .
		Ready to Assemble (RTA): Solid wood Half Blind Dovetail drawer boxes ready to assemble with ears are only available with TE22 or TE24 .
		TE22, TE23 and TE24 are only available on drawer boxes with ears.
3	Bottom Panel Inset Options	Assembled & Ready to Assemble (RTA) drawer boxes with ears are available with all bottom panel inset options.

Notes continued on next page...

► For **PRICING** ► See *Section H.10* in our current Wholesale Pricing Catalog.

Technical Notes: Drawer Box “Ear”...continued

Additional Options (Chapter H)

1	Drawer Box Options	Compatible with the following drawer box options: <ul style="list-style-type: none"> • Shaped Side Patterns (<i>Section H.8</i>) • Scoop Fronts (<i>Section H.9</i>) • Accented Top Edge (<i>Section H.12</i>) • Laser Engraving (<i>Section H.13</i>) • Notched Patterns (<i>Section H.15</i>) See individual drawer box option <i>Sections H.7</i> through <i>H.18</i> for more information, as restrictions may apply.
----------	---------------------------	--

Miscellaneous

1	Drawer Slide Placement	Please keep in mind that if using side mount drawer slides on a drawer box with “Ears”, the slides will have to be set back the thickness of the “Ear” from the front of the box. Please consult drawer slide specifications for drawer box sizing and mounting information. Not compatible with under mount drawer slides.
----------	-------------------------------	---

Ready to Assemble (RTA)

1	Ready to Assemble (RTA)	Please see individual drawer box <i>Sections H.1</i> through <i>H.5</i> for drawer box styles that are compatible with Ready to Assemble (RTA) construction.
----------	--------------------------------	--

Sizes / Dimensions

1	Ear Extension	Drawer Box “Ears” extend $\frac{7}{16}$ " [11.1mm] past the pullout sides.
2	Box Size	When ordering drawer boxes with “Ears”, please order the box size without the “Ear” dimension added.
3	Ear Thickness	The “Ear” thickness varies depending on the thickness of the sidewalls.
		$\frac{1}{2}$ " [12.7mm] Sides - “Ears” are $\frac{1}{4}$ " [6.4mm] thick. Front of drawer box will be $\frac{5}{8}$ " [15.9mm] thick to allow for dovetail joint and $\frac{1}{4}$ " [6.4mm] thick ear.
		$\frac{5}{8}$ " [15.9mm] Sides - “Ears” are $\frac{1}{4}$ " [6.4mm] thick. Front of box will be $\frac{5}{8}$ " [15.9mm] thick.
		$\frac{3}{4}$ " [19.1mm] Sides - “Ears” are $\frac{3}{8}$ " [9.5mm] thick. Front of box will be $\frac{3}{4}$ " [19.1mm] thick.

Top Edge Profile Options

1	“TE22” Top Edge	Top edges are flush and square on all sides.
2	“TE23” Top Edge	Top edges are all flush and eased on all sides.
3	“TE24” Top Edge	Constructed with the sides 3.0mm shorter than the front and back of the box. On $\frac{3}{4}$ " [19.1mm] thick material, the sides are 4.0mm shorter than the front and back of the box.
		All edges are eased.
		When ordering, please give the height dimension using the size for the front and back.

► For PRICING ► See Section **H.10** in our current Wholesale Pricing Catalog.

Drawer Box Options

Hanging File Slots

Hanging File Slot Option

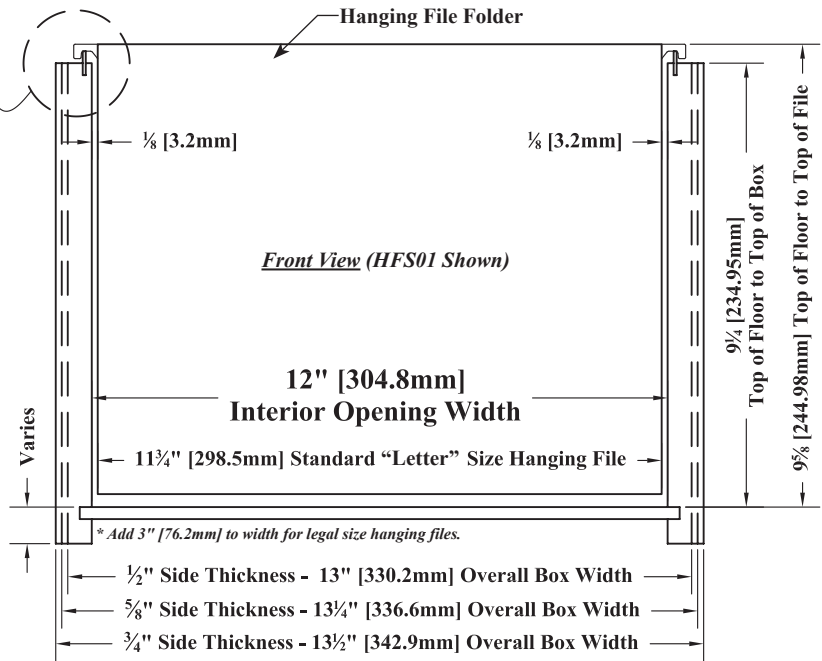
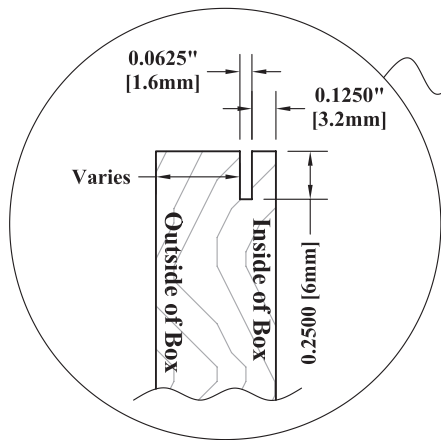

HFS01: Interior drawer box width must be 12" for standard letter size hanging file.

HFS02: Interior drawer box depth must be 12" for standard letter size hanging file.

HFS03: Interior drawer box dimension between front and divider must be 12" for standard letter size hanging files.

HFS01 Slot Placement on Left & Right Sides

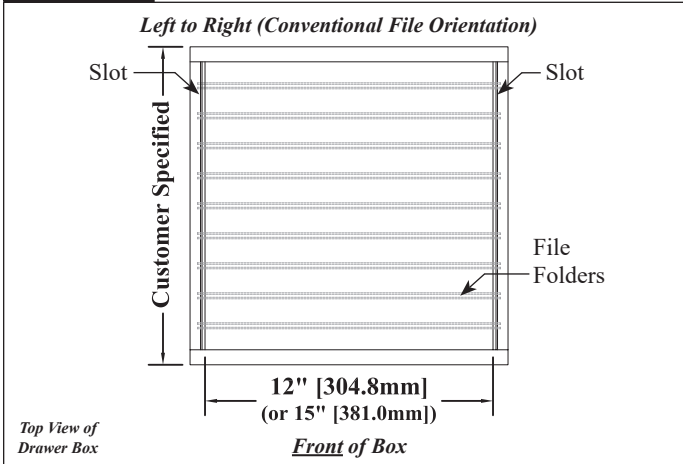

HFS02 Slot Placement on Front & Back

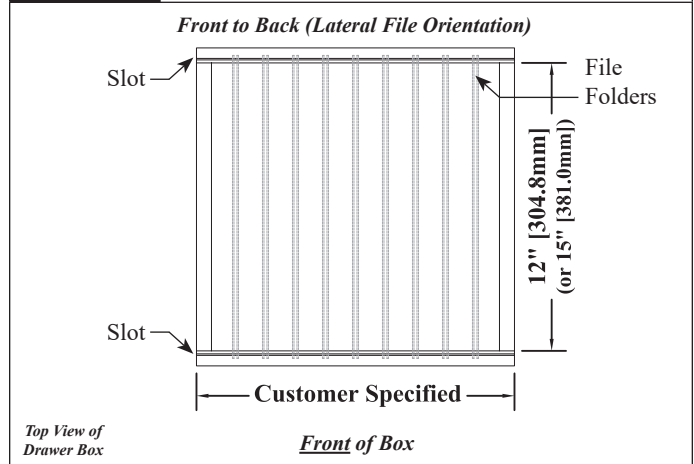

HFS01 Example with TE6

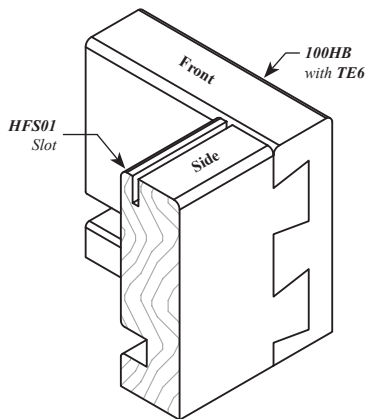

HFS01 Example with TE4



► For PRICING ► See Section H.11 in our current Wholesale Pricing Catalog.

Hanging File Slots

Drawer Box Options

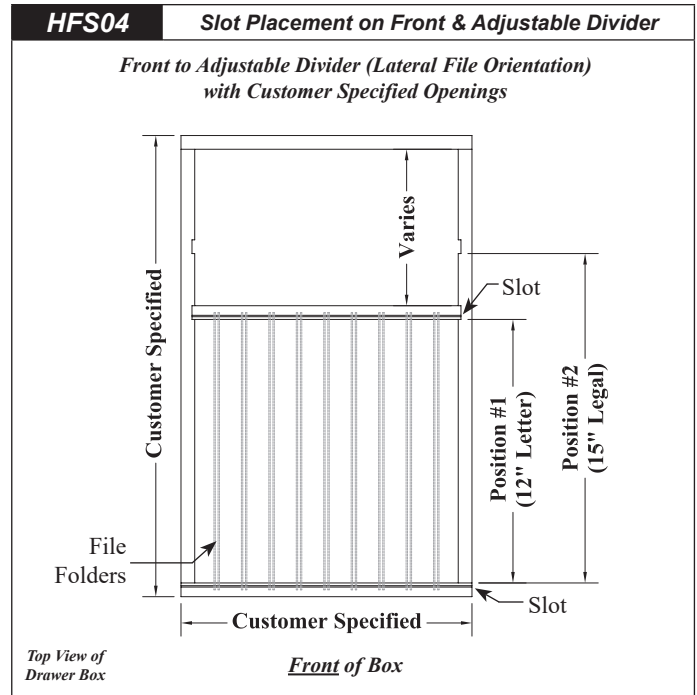
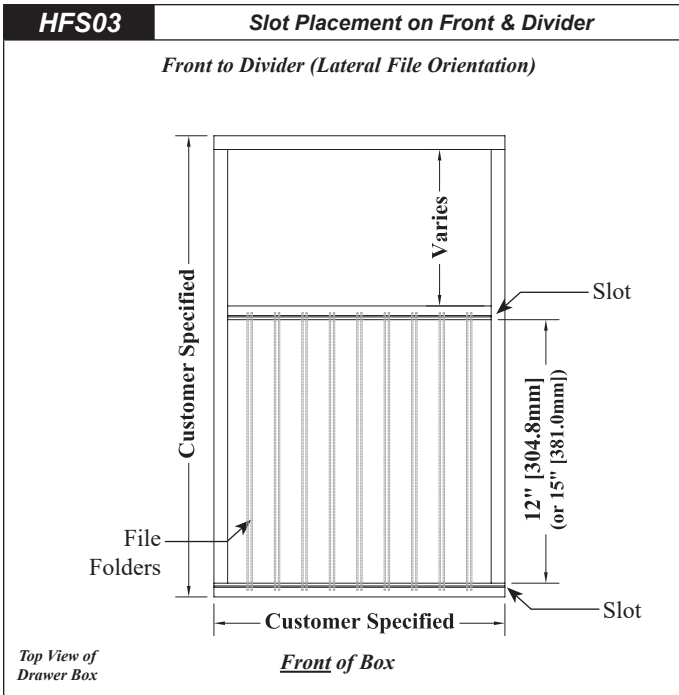

Ordering & Pricing Notes: Hanging File Slot

Ordering Guidelines

1	Order Forms	Please use <i>Drawer Box Order Form (E•Z Form #4)</i> .
2	Ordering Information	To order the Hanging File Slot option on a drawer box, please note Part #HFS01, #HFS02, #HFS03 or #HFS04 in the <i>Special Instructions</i> column on the <i>Drawer Box Order Form (E•Z Form #4)</i> . <ul style="list-style-type: none"> For #HFS03, please also indicate letter size or legal size divider placement. For #HFS04, position #1 will be 12" for letter size and position #2 will be 15" for legal size unless specified otherwise.
3	Aluminum Bar Stock	Cut to size aluminum bar stock will come standard when ordering any of the HFS options. <ul style="list-style-type: none"> Aluminum bar stock will not be installed in the slot; it will be packaged separately and shipped with the drawer boxes. Aluminum bar stock can be ordered separately and cut to size using WCI Item #159741 on the <i>Moldings & Miscellaneous Order Form (E•Z Form #5)</i> . <ul style="list-style-type: none"> Please indicate length and number of pieces (maximum length of 72" [1828.8mm]).

Pricing

1	Pricing	Please see <i>Section H.11</i> of our current Wholesale Pricing Catalog .
---	---------	--

Technical Notes: Hanging File Slot

Required Options (Chapter H)

1	Drawer Box Styles	Please see individual drawer box <i>Sections H.1</i> through <i>H.5</i> for compatible drawer box styles.
2	Top Edge Profile Options	HFS01 only available with TE4, TE6. HFS02 only available with TE2, TE4, TE6, TE7. HFS03 only available with TE4, TE6. HFS04 only available with TE4, TE6.
3	Bottom Panel Inset Options	Assembled & Ready to Assemble (RTA) drawer boxes with hanging file slot are available with all bottom panel inset options.

Notes continued on next page...

► For PRICING ► See Section H.11 in our current Wholesale Pricing Catalog.

Technical Notes: Hanging File Slot...continued

Additional Options (Chapter H)

1	Drawer Box Options	Compatible with the following drawer box options:
		<ul style="list-style-type: none"> • Drawer Slide Notching (<i>Section H.7</i>) • Accented Top Edge (<i>Section H.12</i>) • Laser Engraving (<i>Section H.13</i>)
		See individual drawer box option <i>Sections H.7</i> through <i>H.18</i> for more information, as restrictions may apply.
2	Hanging File Slot and Aluminum Bar Stock Placement	HFS01: Slots will be applied to the left & right sides of the drawer box (<i>conventional</i>).
		• Aluminum bar stock will be notched and extend ½" [12.7mm] beyond the opening depth at each end.
		HFS02: Slots will be applied to the front & back of the drawer box (<i>lateral</i>).
		• Aluminum bar stock will run the full width of the drawer box.
		HFS03: Slots will be applied to the front and the divider of the drawer box (<i>lateral</i>).
		• Front: Aluminum bar stock will run the full width of the drawer box.
		• Divider: Aluminum bar stock will be notched and extend ½" [12.7mm] beyond the divider at each end.
		HFS04: Slots will be applied to the front and the divider of the drawer box (<i>lateral</i>).
		• Front: Aluminum bar stock will run the full width of the drawer box.
		• Divider: Aluminum bar stock will be notched and extend ½" [12.7mm] beyond the opening depth at each end.
3	HFS03 Divider Installation	Divider will be doweled into the sides.
4	HFS04 Divider Installation	Adjustable divider will be dadoed ¼" [3.2mm] into each side.

Ready to Assemble (RTA)

1	Ready to Assemble (RTA)	Drawer boxes with hanging file slots HFS01 & HFS02 are available Ready to Assemble (RTA).
		Drawer boxes with hanging file slots HFS03 & HFS04 are <u>not</u> available Ready to Assemble (RTA).

Sizes / Dimensions

1	Sidewall Thickness	Available with sidewall thicknesses of ½" [12.7mm], ⅝" [15.9mm] and ¾" [19.1mm].
2	Interior Drawer Box Dimension	HFS01: Interior drawer box width must be 12" [304.8mm] for standard letter size hanging files. Add 3" [76.2mm] for standard legal size hanging files.
		HFS02: Interior drawer box depth must be 12" [304.8mm] for standard letter size hanging files. Add 3" [76.2mm] for standard legal size hanging files.
		• Depending on your chosen material thickness, drawer boxes with HFS02 will finish with an overall depth between 13" [330.2mm] and 13½" [342.9mm]. This dimension will be incompatible with most undermount drawer slides. Please consult your drawer slide manufacturer for installation specifications.
		HFS03: Interior drawer box dimension between front and divider must be 12" [304.8mm] for standard letter size hanging files. Add 3" [76.2mm] for standard legal size hanging files.
		HFS04: Customer must specify the interior opening dimensions. Interior drawer box dimension between front and divider must be 12" [304.8mm] for standard letter size hanging files. Add 3" [76.2mm] for standard legal size hanging files, or specify custom measurements for non-standard hanging file sizes.
3	Minimum Drawer Box Depth	Minimum depth for a drawer box with HFS03 and letter size divider placement is 16" [406.4mm].
		Minimum depth for a drawer box with HFS03 and legal size divider placement is 18" [406.4mm].
		Calculate minimum depth for a drawer box with HFS04 by adding 3" [76.2mm] to Position #2 dimension .
4	Minimum Drawer Box Height Formula	The following formula can be used to calculate the overall <i>minimum</i> drawer box height required to hold a letter size hanging file: Letter Size File Folder = 9¼" + Bottom Panel Thickness + Bottom Panel Inset Dimension
5	Cabinet Opening Height	To determine the cabinet opening height for a hanging file drawer box you'll need to factor in: a) The distance between the bottom of the drawer box and the bottom of the cabinet opening. b) The height of any file tabs or labels that protrude beyond the top of the hanging file folder.
6	Aluminum Bar Stock	Aluminum Bar Stock is ½" [12.7mm] high with a maximum length of 72" [1828.8mm].
7	Slot Size Requirements	The slot size required to install WalzCraft's Aluminum Bar stock is: ⅛" Wide x ¼" Deep [1.6mm x 6.4mm].
8	Slot Placement	Standard placement is ¼" [3.2mm] from the inside of the drawer.

► For PRICING ► See Section *H.11* in our current Wholesale Pricing Catalog.

Accented Top Edge

WalzCraft offers the Accented Top Edge which allows you to select a different wood species for construction on the top edge, creating a decorative detail for your drawer box.

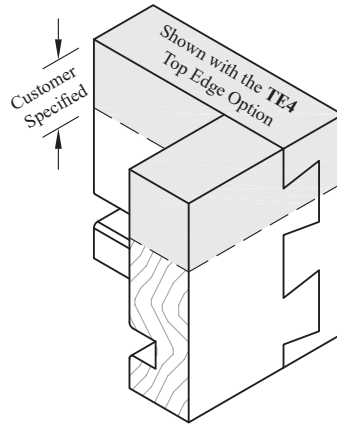

H

Ordering & Pricing Notes: Accented Top Edge

Ordering Guidelines

1	Order Forms	Please use “ <i>Advanced Version</i> ” of the <i>Drawer Box Order Form (E•Z Form #4)</i> . • The drawer box order form will include spaces to indicate your chosen option.
----------	--------------------	---

Pricing

1	Pricing	Please see <i>Section H.12</i> of our current Wholesale Pricing Catalog .
----------	----------------	--

Technical Notes: Accented Top Edge

Required Options (Chapter H)

1	Drawer Box Styles	Please see individual drawer box <i>Sections H.1</i> through <i>H.5</i> for compatible drawer box styles.
2	Top Edge Profile Options	See chosen drawer box style for available top edge profile options.
3	Bottom Panel Inset Options	Assembled & Ready to Assemble (RTA) drawer boxes with accented top edge are available with all bottom panel inset options.

Additional Options (Chapter H)

1	Drawer Box Options	Compatible with the following drawer box options: • Drawer Slide Notching (<i>Section H.7</i>) • Ears (<i>Section H.10</i>) • Hanging File Slot (<i>Section H.11</i>) See individual drawer box option <i>Sections H.7</i> through <i>H.18</i> for more information, as restrictions may apply.
----------	---------------------------	---

Materials

1	Wood Species	These solid wood species are most desirable for an accented top edge: Cherry, Mahogany, Sapele and Walnut.
----------	---------------------	--

Ready to Assemble (RTA)

1	Ready to Assemble (RTA)	Please see individual drawer box <i>Sections H.1</i> through <i>H.5</i> for drawer box styles that are compatible with Ready to Assemble (RTA) construction.
----------	--------------------------------	--

Sizes / Dimensions

1	Width	The width of the edge band must match the drawer box side wall thickness.
2	Height	Must be specified, 1/2" [12.7mm] minimum required.

► **For PRICING** ► See *Section H.12* in our current Wholesale Pricing Catalog.



Drawer Box Laser Engraving

H

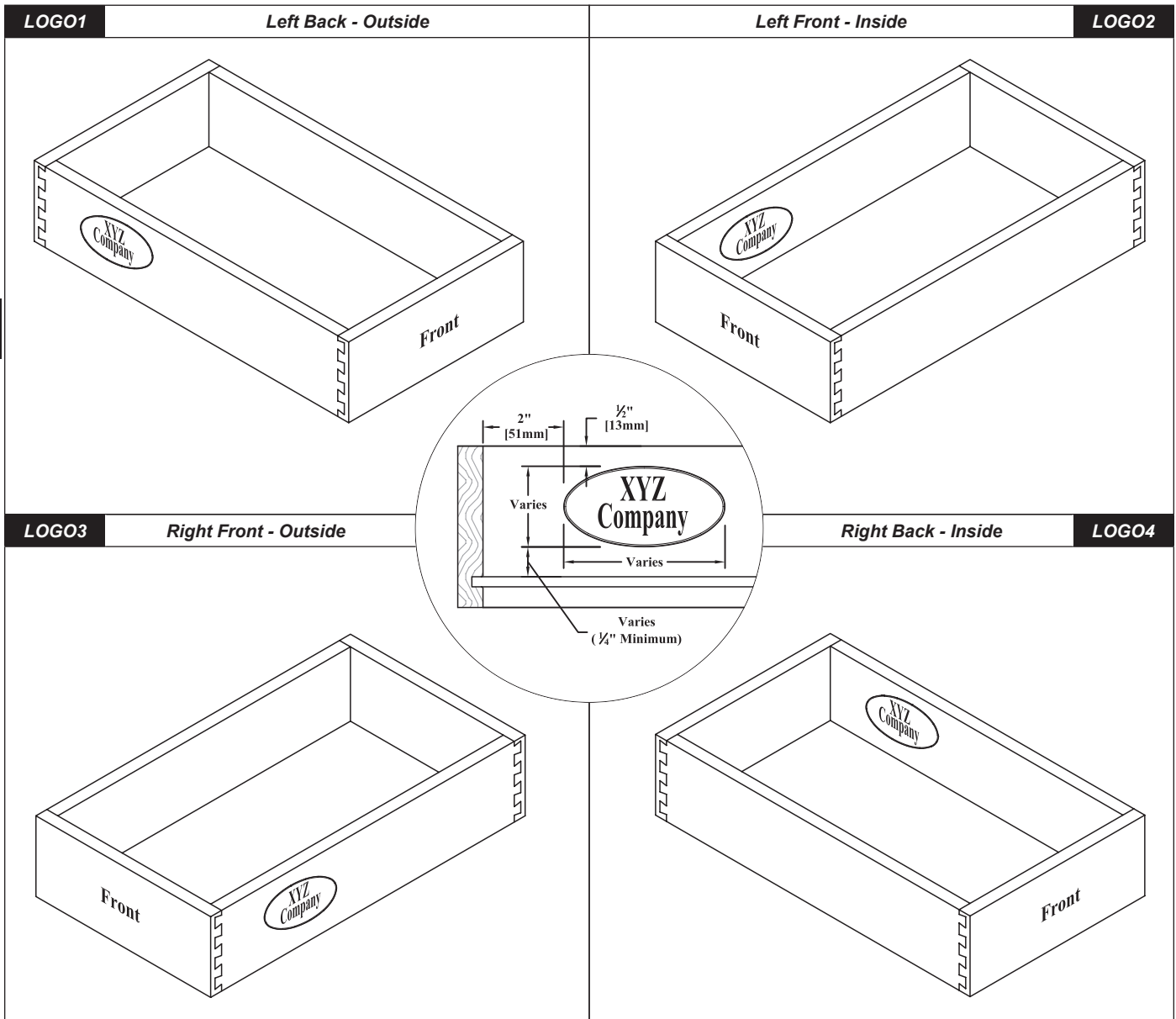

Ordering & Pricing Notes: Laser Engraving

Ordering Guidelines

1	Ordering	Please contact our Customer Support Team with your "Laser Engraving" requests.
2	Ordering information	Business logo designs need to be submitted in one of the following formats: EPS (vector art preferred), high resolution JPEG or TIF files. (JPEG and TIF files must be at least 600 DPI.)
		Due to variations in logo designs, we will provide you with a CAD drawing and a price quote.
		An approval signature to proceed will be required before an order can be placed.

Pricing

1	Pricing	Please see <i>Section H.13</i> of our current Wholesale Pricing Catalog .
----------	----------------	--

Notes continued on next page...

► **For PRICING** ► See *Section H.13* in our current Wholesale Pricing Catalog.

Technical Notes: Laser Engraving

Required Options (Chapter H)

1	Drawer Box Styles	Please see individual drawer box <i>Sections H.1</i> through <i>H.5</i> for compatible drawer box styles.
2	Top Edge Profile Options	See chosen drawer box style for available top edge profile options.
3	Bottom Panel Inset Options	Assembled & Ready to Assemble (RTA) drawer boxes with laser engraving are available with all bottom panel inset options.

Additional Options (Chapter H)

1	Drawer Box Options	<p>Compatible with the following drawer box options:</p> <ul style="list-style-type: none"> • Drawer Slide Notching (<i>Section H.7</i>) • Shaped Side Patterns (<i>Section H.8</i>) • Scoop Front (<i>Section H.9</i>) • Ears (<i>Section H.10</i>) • Hanging File Slot (<i>Section H.11</i>) • Notched Patterns (<i>Section H.15</i>) • Curved Front Patterns (<i>Section H.16</i>) • Inside Corner Patterns (<i>Section H.17</i>) • Drawer Slide Blocking (<i>Section H.18</i>) <p>See individual drawer box option <i>Sections H.7</i> through <i>H.18</i> for more information, as restrictions may apply.</p>
---	---------------------------	--

Ready to Assemble (RTA)

1	Ready to Assemble (RTA)	Please see individual drawer box <i>Sections H.1</i> through <i>H.5</i> for drawer box styles that are compatible with Ready to Assemble (RTA) construction.
---	--------------------------------	--

Sizes / Dimensions

1	Maximum Size	Maximum part size for any image is 24" wide x 36" high.
2	Logo Size	<p>Formula used to calculate your logo height:</p> <ul style="list-style-type: none"> • The height dimension of your shortest drawer box will be used in the formula to calculate your logo height. • Allow ½" of space between the top edge of the drawer box and the top of the logo. • Allow ¼" minimum of space between the bottom of the logo and the top of the bottom panel, measuring from the inside of the box. • Your logo height will be the distance between the above two points. The width will be proportionate to the submitted drawing, given the calculated logo height. <p>This logo height will then be used throughout the entire order, even though drawer box heights may vary.</p> <p>Once you establish a certain size logo, it will be kept on file for future use. Multiple sizes can be saved.</p>
3	Placement	<p>Standard location for logo can be any one of the four positions shown in the drawings on the previous page.</p> <ul style="list-style-type: none"> • The edge/side of the logo will always measure 2" in from the inside of the drawer box front/back. • The top of the logo will always be placed ½" down from the top edge of the drawer box. • The space between the bottom of the logo and the top of the bottom panel will vary as drawer box heights vary. <p>Please submit requests for custom logo placement to our Customer Support Team, as additional charges may apply.</p>

Wood Specie Options (Chapter S)

1	Recommended Species	<p>All solid wood species are available with laser engraving, but the following are most suitable:</p> <ul style="list-style-type: none"> • Alder, Cherry, Maple, Red Birch and Walnut. • Baltic Birch plywood is also an available option.
---	----------------------------	---

► For PRICING ► See Section H.13 in our current Wholesale Pricing Catalog.

Bread Box Slideback Lid Option (BBSL100)

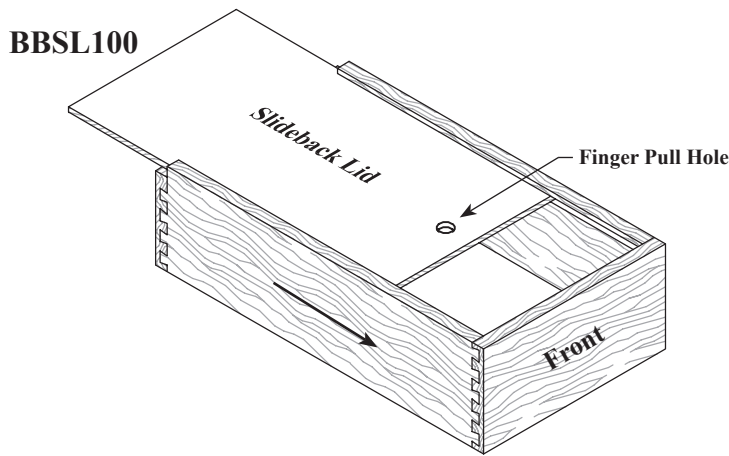

H

Ordering & Pricing Notes: Bread Box Slideback Lids

Ordering Guidelines

1	Order Forms	Please use <i>Drawer Box Order Form (E-Z Form #4)</i> . • The drawer box order form will include spaces to indicate your chosen option.
Pricing		
1	Pricing	Please see <i>Section H.14</i> of our current Wholesale Pricing Catalog .

Technical Notes: Bread Box Slideback Lids

Required Options (Chapter H)

1	Drawer Box Styles	Please see individual drawer box <i>Sections H.1</i> through <i>H.5</i> for compatible drawer box styles.
2	Top Edge Options	Only available with TE2, TE4, TE6 and TE7 .
3	Bottom Panel Inset Options	Assembled drawer boxes with bread box slideback lids are only available with 1/4" [6.4mm] thick bottom panels inset at 8.0mm, 10.0mm, 12.0mm or 13.0mm.

Additional Options (Chapter H)

1	Drawer Box Options	Compatible with the following drawer box options: • Drawer Slide Notching (Section H.7) ◦ Assembled drawer boxes with bread box slideback lids are available with all drawer slide notching options except DBN500 . See <i>Section H.7</i> . See individual drawer box option <i>Sections H.7</i> through <i>H.18</i> for more information, as restrictions may apply.
----------	---------------------------	---

Finish Options (Chapter R)

1	Natural / Clear Coat (no stain)	When the drawer box is unfinished, the wood veneer Bread Box Slideback Lid will be unfinished. When the drawer box is finished with WalzCraft's <i>water base</i> "Natural / Clear Coat (no stain)" finish, the wood veneer Bread Box Slideback Lid will have the same finish. Bread Box Slideback Lids are finished on 2-sides (2S).
----------	--	---

General Information (Chapter A)

1	Grain Direction	Grain direction for slideback lids can be specified to run front to back, left to right or random.
----------	------------------------	--

Material Options

1	Sliding Lid Material	Bread Box Slideback Lids (BBSL100) are available in all of the same wood species as drawer box bottom panels (includes melamine). See <i>Section H.6</i> of our current Wholesale Pricing Catalog .
----------	-----------------------------	---

Notes continued on next page...

► **For PRICING** ► See *Section H.14* in our current Wholesale Pricing Catalog.

Technical Notes: Bread Box Slideback Lids...continued

Ready to Assemble (RTA)

1	Ready to Assemble (RTA)	Drawer boxes with bread box slideback lids are not available Ready to Assemble (RTA).
----------	--------------------------------	---

Sizes / Dimensions

1	Top Thickness	Available in ¼" [6.4mm] thickness only.
2	Sidewall Thickness	Available with sidewall thicknesses of ½" [12.7mm], ⅝" [15.9mm] and ¾" [19.1mm].
3	Drawer Box Sizes	Available on drawer boxes that are 22" [558.8mm] wide or less.
4	Groove Location	Grooves for the Bread Box Slideback Lid will start at 8.0mm down from the top of the drawer box and will be applied to the sides and the front of the box.
5	Finger Pull Hole	Finger pull hole will be 1½" [38.1mm] in diameter, set back ¾" [19.1mm] from the front edge of the lid and centered on the width.

► For PRICING ► See Section *H.14* in our current Wholesale Pricing Catalog.

Notched Patterns

⊙ = Example of plumbing obstruction for Drawer Box Styles DBP101, DBP102L, DBP102R.

Left Side of Box
to Left Side
of Opening

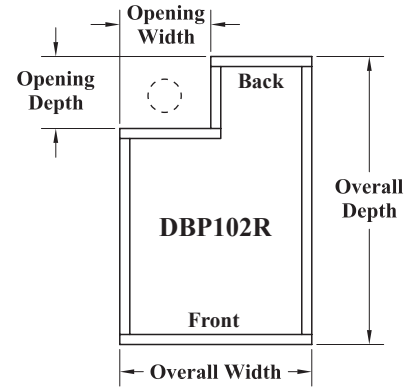
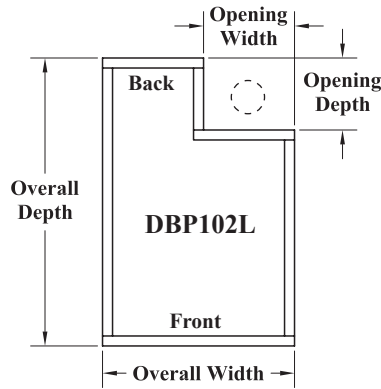
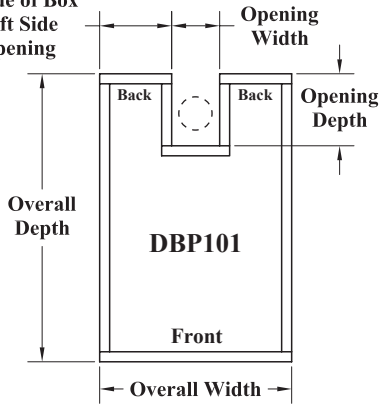

H

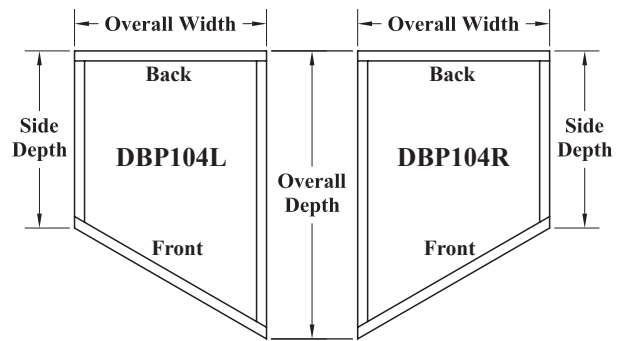
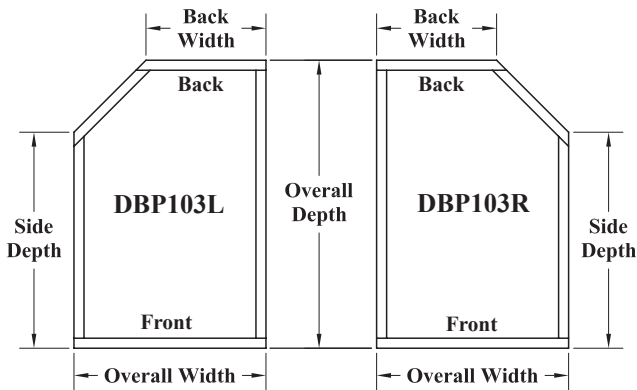

Notched Patterns can be combined with Curved Front drawer boxes from Section H.17. See notes for more information.

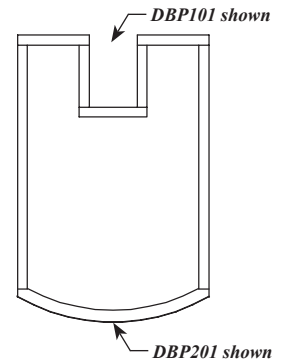

► For PRICING ► See Section H.15 in our current Wholesale Pricing Catalog.

Ordering & Pricing Notes: Notched Patterns

Ordering Guidelines

1	Order Forms	Please use “ <i>Advanced Version</i> ” of the <i>Drawer Box Order Form (E•Z Form #4)</i> .
2	Ordering Information	On each of the drawings in this section you will find the information that is required for ordering. <ul style="list-style-type: none"> • Spaces will be provided on the order form for the overall width and overall depth of the drawer box. • All other required dimensions should be noted in the <i>Special Instructions</i> column.
Pricing		
1	Pricing	Please see <i>Section H.15</i> of our current Wholesale Pricing Catalog .

Technical Notes: Notched Patterns

Required Options (Chapter H)

1	Drawer Box Styles	Please see individual drawer box <i>Sections H.1</i> through <i>H.5</i> for compatible drawer box styles.
2	Top Edge Profile Options	See chosen drawer box style for available top edge profile options. <ul style="list-style-type: none"> • Assembled drawer boxes with notched patterns are not available with TE5.
3	Bottom Panel Inset Options	Assembled drawer boxes with notched patterns are available with all bottom panel inset options.

Additional Options (Chapter H)

1	Drawer Box Options	<p>Compatible with the following drawer box options:</p> <ul style="list-style-type: none"> • Drawer Slide Notching (<i>Section H.8</i>) <ul style="list-style-type: none"> ◦ DBP101 available with NHH1, DBN100, DBN200. <ul style="list-style-type: none"> ▪ DBN100, DBN200 notch available in 1/4" increments with a maximum width of 2" [50.8mm]. ◦ DBP104L/R available with NHH1, DBN100, DBN300, DBN500. <ul style="list-style-type: none"> ▪ DBN100, DBN300 notch available in 1/4" increments with a maximum width of 2" [50.8mm]. ◦ DBP102L/R, DBP103L/R not available with any notching options. ◦ When using undermount drawer slides supplied by WalzCraft, please see <i>Sections I.2</i> and <i>I.9</i> for minimum drawer box width given the use of front locking clips. • Side Patterns (<i>Section H.8</i>) • Scoop Fronts (<i>Section H.9</i>) <ul style="list-style-type: none"> ◦ DBP101, DBP102L/R, DBP103L/R available with all scoop front options. • Ears (<i>Section H.10</i>) <ul style="list-style-type: none"> ◦ DBP101, DBP102L/R, DBP103L/R available with ears. • Laser Engraving (<i>Section H.13</i>) • Curved Front Patterns (<i>Section H.16</i>) <ul style="list-style-type: none"> ◦ DBP101, DBP102L/R and DBP103L/R available with all curved front patterns. • Drawer Slide Blocking (<i>Section H.18</i>) <ul style="list-style-type: none"> ◦ DBP104L/R available with the DSB100 drawer slide blocking option. <p>See individual drawer box option <i>Sections H.7</i> through <i>H.18</i> for more information, as restrictions may apply.</p>
---	--------------------	---

Miscellaneous

1	Application	These notched patterns would typically be used to get around plumbing or other types of obstructions inside cabinets.
---	-------------	---

Ready to Assemble (RTA)

1	Ready to Assemble (RTA)	Drawer boxes with notched patterns are not available Ready to Assemble (RTA).
---	-------------------------	---

Sizes / Dimensions

1	Angle Limitations	DBP103L/R & DPB104L/R: These patterns cannot go below a 45° angle or exceed a 135° angle, for dovetailing purposes.
2	Customer Specified Drawer Box Sizes and Undermount Slides	Specifying the correct Drawer Box Size on the WalzCraft order form when the Drawer Box is angled or Curved and the Drawer Slides are Undermount: WalzCraft always recommends that our customers, in their own shop, build a trial mock up of the installed drawer box using the actual type and length of drawer slide intended for use in the final installation. There are many variables to consider for installations of this type. Experience has shown that the best way to determine if the movement of the drawer box will be as required is to do a trial mock up.
3	Minimum Opening Width	When using drawer slide notching, the minimum inside opening width at the “ <i>back</i> ” of box for DBP101 and will equal the drawer slide notch width plus 1/4" [6.35mm]. <ul style="list-style-type: none"> • See <i>Section H.7</i> for more information on drawer slide notching.
4	Minimum Part Sizes	If a part size falls below 3 1/2" [88.9mm] in length, a CAD drawing must be approved prior to manufacturing the product, as dowel joinery may replace half blind dovetail joinery to assemble a particular joint.

► For PRICING ► See *Section H.15* in our current Wholesale Pricing Catalog.

Curved Front Patterns

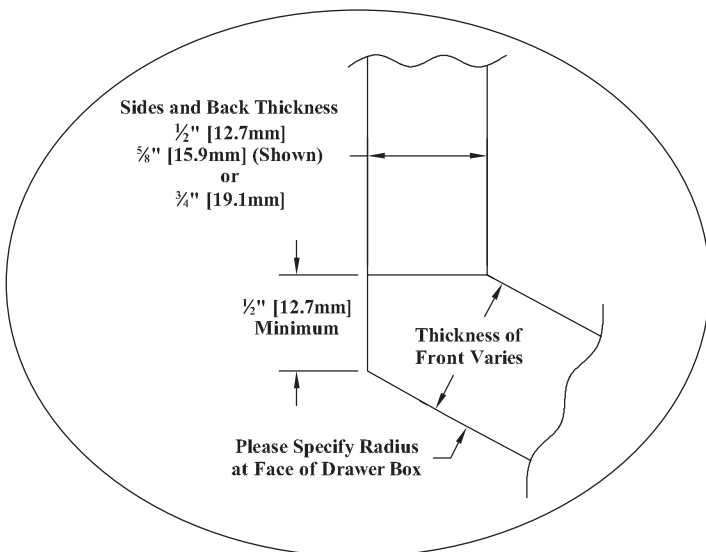
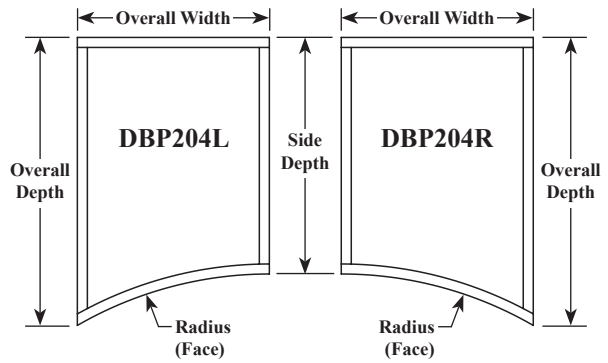
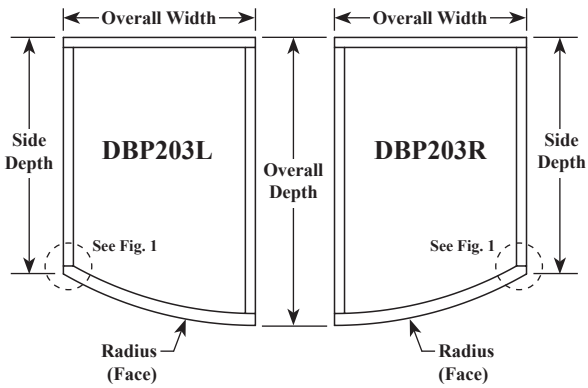
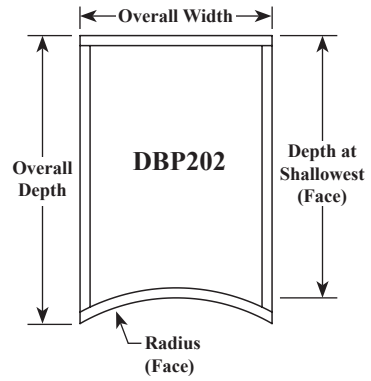
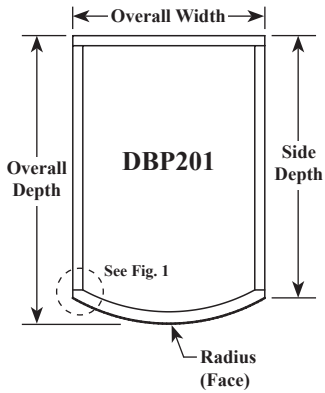
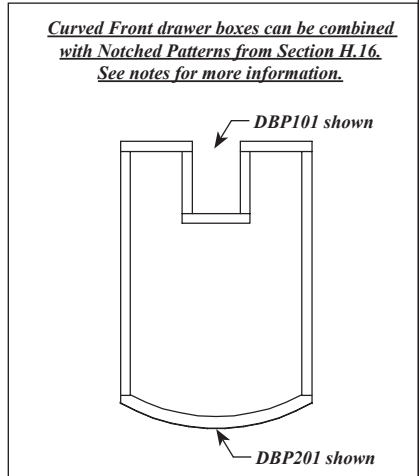

Figure 1



► For PRICING ► See Section H.16 in our current Wholesale Pricing Catalog.

Ordering & Pricing Notes: Curved Front Patterns

Ordering Guidelines

1	Order Forms	Please use <i>Drawer Box Order Form (E•Z Form #4)</i> .
2	Ordering Information	On each of the drawings you will find the information that is required for ordering.

Pricing

1	Pricing	Please see <i>Section H.16</i> of our current Wholesale Pricing Catalog .
---	---------	--

Technical Notes: Curved Front Patterns

Required Options (Chapter H)

1	Drawer Box Styles	Please see individual drawer box <i>Sections H.1</i> through <i>H.5</i> for compatible drawer box styles. Curved front drawer boxes will use half blind dovetail joints, where the front meets the sides, whenever possible. In the event that this joint is beyond our capabilities with your chosen configuration and radius, WalzCraft will build the box using an alternatively suitable joinery method.
2	Top Edge Profile Options	See chosen drawer box style for available top edge profile options. • Assembled drawer boxes with curved front patterns are not available with TE5 .
3	Bottom Panel Inset Options	Assembled drawer boxes with curved front patterns are available with all bottom panel inset options.

Additional Options (Chapter H)

1	Drawer Box Options	Compatible with the following drawer box options: <ul style="list-style-type: none"> • Drawer Slide Notching (<i>Section H.7</i>) <ul style="list-style-type: none"> ◦ All curved front drawer boxes are available with NHH1, DBN100, DBN300, DBN500 only. <ul style="list-style-type: none"> ▪ DBN100, DBN300 notch available in 1/4" increments with a maximum width of 2" [50.8mm]. ◦ When using undermount drawer slides supplied by WalzCraft, please see <i>Sections I.2</i> and <i>I.8</i> for minimum drawer box width given the use of front locking clips. • Scoop Fronts (<i>Section H.9</i>) <ul style="list-style-type: none"> ◦ All curved front patterns are available with all scoop front options. ◦ Curved front drawer boxes with scoop fronts are only available with square top edges TE2 and TE4. • Laser Engraving (<i>Section H.13</i>) • Notched Patterns (<i>Section H.15</i>) <ul style="list-style-type: none"> ◦ All curved front drawer boxes are available with DBP101, DBP102L/R and DBP103L/R notched patterns. • Drawer Slide Blocking (<i>Section H.18</i>) <ul style="list-style-type: none"> ◦ All curved front drawer boxes are available with the DSB100 drawer slide blocking option. <p>See individual drawer box option <i>Sections H.7</i> through <i>H.18</i> for more information, as restrictions may apply.</p>
---	--------------------	--

Ready to Assemble (RTA)

1	Ready to Assemble (RTA)	Drawer boxes with curved front patterns are not available Ready to Assemble (RTA).
---	-------------------------	--

Sizes / Dimensions

1	Maximum Height	The maximum height for any curved front drawer box is 13" [330.2mm].
2	Specified Radius	The radius must be specified at the face of the curve when ordering.
3	Drawer Front Radius	If a matching drawer front is being ordered with one of these designs, the radius for the drawer box will be determined from the radius of the drawer front.
4	DBP201, DBP203L/R	Due to the radius of these styles, the front may be thicker than the remaining sides. <i>See Figure 1</i> at bottom of previous page.
5	Customer Specified Drawer Box Sizes and Undermount Slides	Specifying the correct drawer box size on the WalzCraft order form when the drawer box is angled or curved and the drawer slides are undermount: WalzCraft always recommends that our customers, in their own shop, build a trial mock up of the installed drawer box using the actual type and length of drawer slide intended for use in the final installation. There are many variables to consider for installations of this type. Experience has shown that the best way to determine if the movement of the drawer box will be as required is to do a trial mock up.

► For PRICING ► See *Section H.16* in our current Wholesale Pricing Catalog.

Half Blind Dovetail Drawer Boxes - Inside Corner Patterns - Solid Wood & Baltic Birch

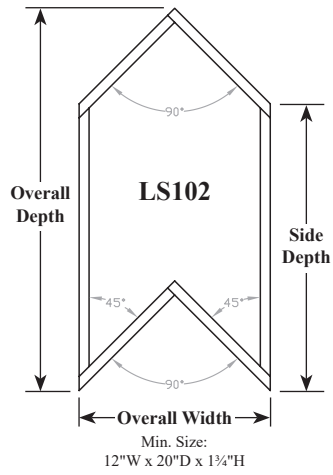
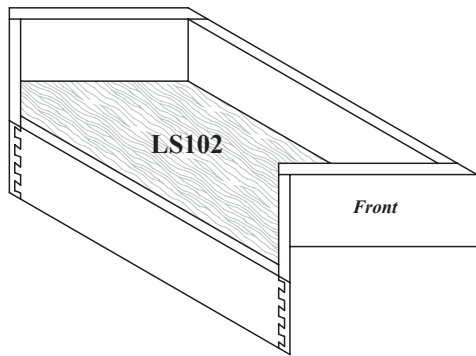
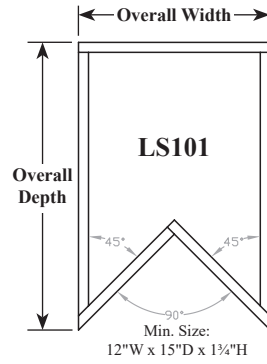
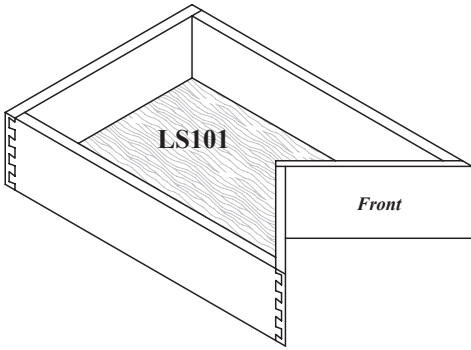

H

► For PRICING ► See Section *H.17* in our current Wholesale Pricing Catalog.

Ordering & Pricing Notes: Inside Corner Patterns

Ordering Guidelines

1	Order Forms	Please use “ <i>Advanced Version</i> ” of the <i>Drawer Box Order Form (E•Z Form #4)</i> .
2	Ordering Information	On each of the drawings in this section you will find the information that is required for ordering. <ul style="list-style-type: none"> • Spaces will be provided on the order form for the overall width and overall depth of the drawer box. • All other required dimensions should be noted in the <i>Special Instructions</i> column.
Pricing		
1	Pricing	Please see <i>Section H.17</i> of our current Wholesale Pricing Catalog .

Technical Notes: Inside Corner Patterns

Required Options (Chapter H)

1	Drawer Box Styles	Please see individual drawer box <i>Sections H.1</i> through <i>H.5</i> for compatible drawer box styles.
2	Top Edge Profile Options	See chosen drawer box style for available top edge profile options. <ul style="list-style-type: none"> • Assembled drawer boxes with inside corner patterns are not available with TE5 or TE14.
3	Bottom Panel Inset Options	Assembled drawer boxes with inside corner patterns are available with all bottom panel inset options.

Additional Options (Chapter H)

1	Drawer Box Options	<p>Compatible with the following drawer box options:</p> <ul style="list-style-type: none"> • Drawer Slide Notching (<i>Section H.7</i>) <ul style="list-style-type: none"> ◦ LS101 is available with the DBN100, DBN300 and DBN500 drawer slide notching options. ◦ LS101 is available with the NHH1 drawer slide notching option when used in conjunction with the DSB100 drawer slide blocking option. ◦ LS102 is available with the NHH1 drawer slide notching option when used in conjunction with the DSB200 drawer slide blocking option. • Laser Engraving (<i>Section H.13</i>) • Drawer Slide Blocking (<i>Section H.18</i>) <ul style="list-style-type: none"> ◦ LS101 is available with the DSB100 drawer slide blocking option. ◦ LS102 is available with the DSB200 drawer slide blocking option. <p>See individual drawer box option <i>Sections H.7</i> through <i>H.18</i> for more information, as restrictions may apply.</p>
---	--------------------	--

Hardware (Chapter I)

1	Drawer Slide Release Clips	<p>All assembled drawer box styles are available with undermount drawer slide release clips/locking devices installed. Please see <i>Chapter I</i> of the Product Specifications Catalog for more information.</p> <p>Must be used in conjunction with Drawer Slide Blocking (DSB100, DSB200). See <i>Section H.18</i>.</p>
---	----------------------------	--

Ready to Assemble (RTA)

1	Ready to Assemble (RTA)	Drawer boxes with inside corner patterns are not available Ready to Assemble (RTA).
---	-------------------------	---

Sizes / Dimensions

1	Minimum Height	Minimum height of Inside Corner Drawer Boxes is 1¼" [44.5mm].
2	Inside Corner Angle	Only available with 45° / 90° angles (as shown on previous page).
3	Customer Specified Drawer Box Sizes and Undermount Slides	Specifying the correct Drawer Box Size on the WalzCraft order form when the Drawer Box is angled or Curved and the Drawer Slides are Undermount: WalzCraft always recommends that our customers, in their own shop, build a trial mock up of the installed drawer box using the actual type and length of drawer slide intended for use in the final installation. There are many variables to consider for installations of this type. Experience has shown that the best way to determine if the movement of the drawer box will be as required is to do a trial mock up.

► For PRICING ► See Section H.17 in our current Wholesale Pricing Catalog.

DSB100 - Drawer Slide Blocking for Undermount Drawer Slides (Includes Front Blocks Only)

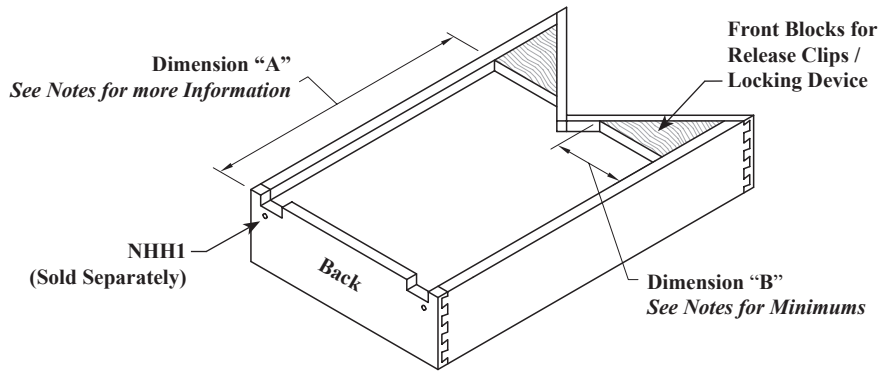

Bottom of Inside Corner Drawer Box LS101 shown.

DSB200 - Drawer Slide Blocking for Undermount Drawer Slides (Includes Front and Back Blocks)

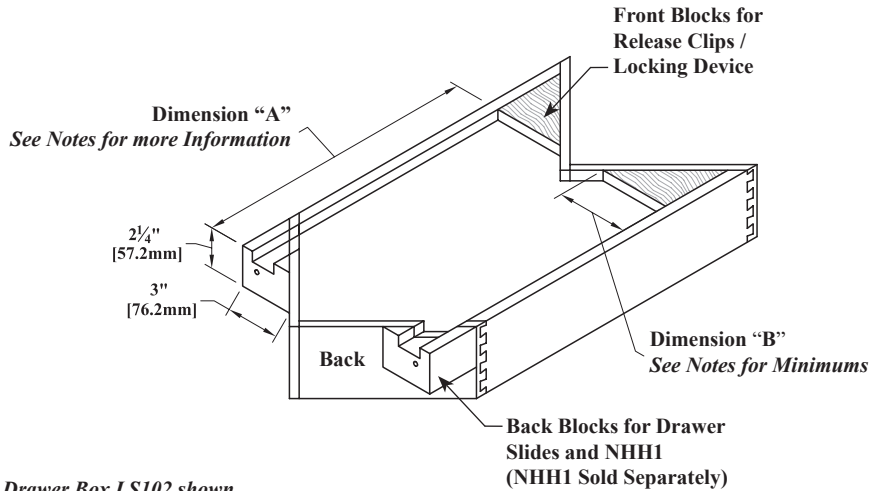

Bottom of Inside Corner Drawer Box LS102 shown.

► For PRICING ► See Section **H.18** in our current Wholesale Pricing Catalog.

Drawer Slide Blocking

Drawer Box Options

Ordering & Pricing Notes: Drawer Slide Blocking

Ordering Guidelines

1	Order Forms	Please use "Advanced Version" of the <i>Drawer Box Order Form (E-Z Form #4)</i> . • The drawer box order form will include spaces to indicate your chosen options.
2	Ordering Information	When ordering an inside corner drawer box (LS101 or LS102) from <i>Section H.17</i> with Drawer Slide Blocking (DSB100 or DSB200) from <i>Section H.18</i> , you must also indicate the following information on the order form: • Indicate LS101 or LS102 and DSB100 or DSB200 in the box designated for these options. • Check mark the box for Inside Corner DB where appropriate to indicate which drawer boxes are to be inside corners. • List the length of your undermount drawer slide (ie: 9", 12", 15", 18", 21") in the <i>Special Instructions</i> column. • See <i>Sizes/Dimnesions</i> notes below for more information regarding dimensions A and B from the illustration.
Pricing		
1	Pricing	Please see <i>Section H.18</i> of our current Wholesale Pricing Catalog .

Technical Notes: Drawer Slide Blocking

Required Options (Chapter H)

1	Drawer Box Styles	Please see individual drawer box <i>Sections H.1</i> through <i>H.5</i> for compatible drawer box styles.
2	Top Edge Profile Options	See chosen drawer box style for available top edge profile options.
3	Bottom Panel Inset Options	Assembled drawer boxes with drawer slide blocking are only available with a 13.0mm bottom panel inset.

Additional Options (Chapter H)

1	Drawer Box Options	Compatible with the following drawer box options: • Drawer Slide Notching (<i>Section H.7</i>) ◦ Drawer slide blocking must be used in conjunction with the NHH1 drawer slide notching option (ordered separately). • Notched Patterns (<i>Section H.15</i>) ◦ DSB100 is available with the DBP104L/R notched patterns. • Curved Front Patterns (<i>Section H.16</i>) ◦ DSB100 is available with all curved front patterns. • Inside Corner Patterns (<i>Section H.17</i>) ◦ DSB100 is available with the LS101 inside corner pattern. ◦ DSB200 is available with the LS102 inside corner pattern. See individual drawer box option <i>Sections H.7</i> through <i>H.10</i> for more information, as restrictions may apply.
2	Installation	When ordering Drawer Slide Blocks for undermount drawer slides, WalzCraft fits and installs the front blocks so that they are mounted flush with the bottom edge of the drawer box providing you with a straight edge to attach the release clip / locking device, which is part of the undermount drawer slide system. The rear blocks are installed to provide a place for the NHH1 to be applied, which accepts the drawer slides. Release clips/locking devices can be ordered separately or ordered and installed by WalzCraft (<i>See Sections I.2 and I.9</i>).

Ready to Assemble (RTA)

1	Ready to Assemble (RTA)	Drawer boxes with drawer slide blocking are not available Ready to Assemble (RTA).
---	-------------------------	--

Sizes/Dimensions

1	Dimensions A & B	Dimension A is determined by the undermount drawer slide: • For Salice drawer slides model A7555 and A7557 , Dimension A = Drawer Length minus Drawer Box Side Material Thickness. See <i>Section I.2</i> . • For Blum drawer slide model 563H , Dimension A = Drawer Length minus Drawer Box Side Material Thickness. See <i>Section I.9</i> . Dimension B is determined by the front locking clips: • For Salice front locking clips model A710.610 and A750.010 , Dimension B = 4" minimum (see <i>Section I.2</i>). • For Blum front locking clip model T51.1901 L/R , dimension B = 3 ³ / ₈ " minimum (see <i>Section I.9</i>). • For Blum front locking clip model T51.0801.20 L/R , Dimension B = 1 ¹ / ₈ " minimum (see <i>Section I.9</i>). For drawer slides and front locking clips other than those listed above, please consult the drawer slide manufacturer for determining dimensions A and B .
2	Customer Specified Drawer Box Sizes and Undermount Slides	Specifying the Correct Drawer Box Size on the WalzCraft Order Form When the Drawer Box is Angled or Curved and the Drawer Slides are Undermount: WalzCraft always recommends that our customers, in their own shop, build a trial/mock-up of the installed drawer box using the actual type and length of drawer slide intended for use in the final installation. There are many variables to consider for installations of this type. Experience has shown that the best way to determine if the movement of the drawer box will be as required is to build a trial/mock-up.

► For PRICING ► See *Section H.18* in our current Wholesale Pricing Catalog.

No Glue-Up Option (NGU100)

WalzCraft offers the **No Glue-Up (NGU)** Option which guarantees a single, solid board will be used for each of the drawer box side walls, front and back.

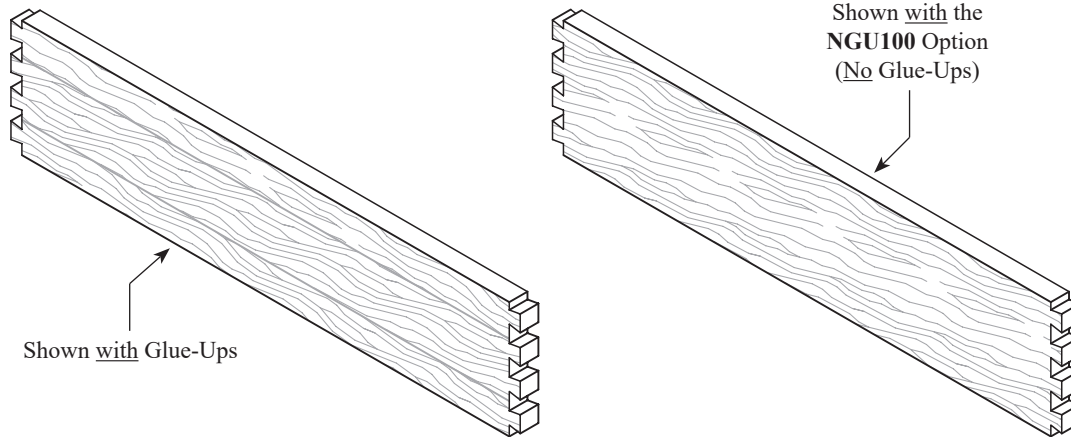

****Only Available for Drawer Box Heights 6" [152.4mm] and under****

Ordering & Pricing Notes: No Glue-Up Option

Ordering Guidelines

1	Order Forms	Please use Drawer Box Order Form (E•Z Form #4) . • The drawer box order form will include spaces to indicate your chosen option.
2	Ordering Information	To order the No Glue-Up Option on a drawer box, please note " NGU100 " in the Special Instructions column on the drawer box order form.
Pricing		
1	Pricing	Please see Section H.19 of our current Wholesale Pricing Catalog .

Technical Notes: No Glue-Up Option

Required Options (Chapter H)

1	Drawer Box Styles	Please see individual drawer box Sections H.1 through H.5 for compatible drawer box styles.
2	Top Edge Profile Options	Assembled drawer boxes with the No Glue-Up option are available with TE1, TE2, TE3, TE4, TE5, TE6, TE7 . Ready to Assemble (RTA) drawer boxes with the No Glue-Up Option are available with TE1, TE2, TE4, TE6, TE7 .
3	Bottom Panel Inset Options	Assembled & Ready to Assemble (RTA) drawer boxes with No Glue-Up Option are available with all bottom panel inset options.

Additional Options (Chapter H)

1	Drawer Box Options	Compatible with the following drawer box options: <ul style="list-style-type: none"> • Drawer Slide Notching (Section H.7) • Scoop Fronts (Section H.9) • Ears (Section H.10) • Laser Engraving (Section H.13) • Bread Box Slideback Lid (Section H.14) • Notched Patterns (Section H.15) • Inside Corner Patterns (Section H.17) • Drawer Slide Blocking (Section H.18) See individual drawer box option Sections H.8 through H.20 for more information, as restrictions may apply.
---	--------------------	---

Material Options

1	Wood Species	The No Glue-Up Option is only available with Natural/Standard Grade or Select/Premium materials. • Not available in specific cuts (i.e. Quarter Sawn, Rift Sawn, etc.).
---	--------------	---

Notes continued on next page...

► **For PRICING** ► See **Section H.19** in our current Wholesale Pricing Catalog.

Technical Notes: No Glue-Up Option...continued

Miscellaneous

1	Glue-Up Options	<p>Drawer Box Heights 6" [152.4mm] and Under: WalzCraft makes every attempt to produce these drawer box parts from one solid piece of wood. Due to lumber availability and/or wood species, parts for drawer boxes with heights 6" [152.4mm] and under may need to be made from two or more edge glued pieces. You may request the No Glue-Up Option (NGU100) to ensure that each part will be built from one solid piece of wood.</p>
		<p>Drawer Box Heights over 6" [152.4mm]: The No Glue-Up Option (NGU100) is not available for drawer boxes with heights over 6" [152.4mm]. WalzCraft will use edge glued pieces wherever necessary.</p>

Ready to Assemble (RTA)

1	Ready to Assemble (RTA)	Please see individual drawer box <i>Sections H.1</i> through <i>H.5</i> for drawer box styles that are compatible with Ready to Assemble (RTA) construction.
---	-------------------------	--

Sizes / Dimensions

1	Sidewall Thicknesses	Available with sidewall thicknesses of 1/2" [12.7mm], 5/8" [15.9mm] and 3/4" [19.1mm].
---	----------------------	--

H

► For PRICING ► See Section **H.19** in our current Wholesale Pricing Catalog.

Drawer Boxes

Drawer Box Organizer Inserts (DBOI)

Series 100 - Drawer Box Organizer Inserts - DBOI (Solid Wood)

**** Vertical dividers are equally spaced. ****

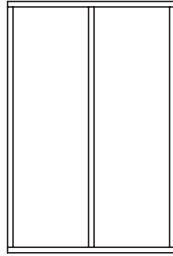
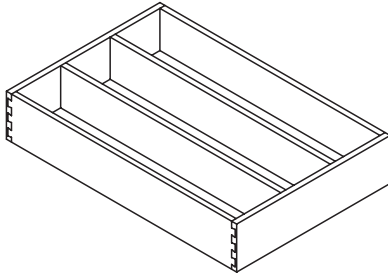

Style: DBOI 101
Min. Size: $3\frac{1}{8}W \times 1\frac{1}{4}D$
(79mm x 45mm)

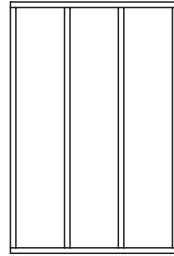

Style: DBOI 102
Min. Size: $4\frac{1}{2}W \times 1\frac{1}{4}D$
(114mm x 45mm)

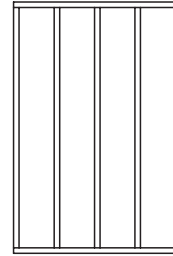

Style: DBOI 103
Min. Size: $5\frac{7}{8}W \times 1\frac{1}{4}D$
(149mm x 45mm)

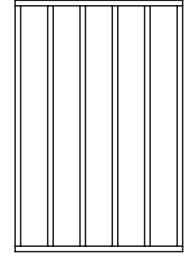

Style: DBOI 104
Min. Size: $7\frac{1}{4}W \times 1\frac{1}{4}D$
(184mm x 45mm)

H

Series 200 - Drawer Box Organizer Inserts - DBOI (Solid Wood)

****Vertical dividers are equally spaced across the width of the organizer.****

****Height of horizontal openings (Dimensions A & B) are customer specified and must be provided.****

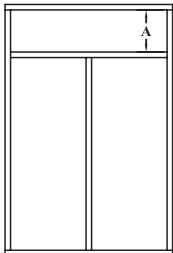

Style: DBOI 201
Min. Size: $3\frac{1}{8}W \times 3\frac{1}{8}D$
(79mm x 79mm)

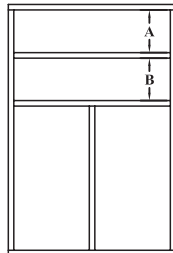

Style: DBOI 202
Min. Size: $3\frac{1}{8}W \times 4\frac{1}{2}D$
(79mm x 114mm)

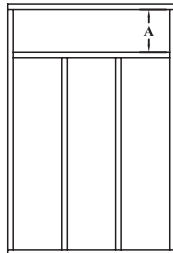

Style: DBOI 203
Min. Size: $4\frac{1}{2}W \times 3\frac{1}{8}D$
(114mm x 79mm)

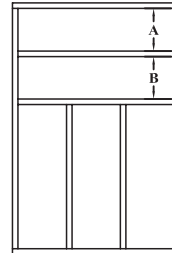

Style: DBOI 204
Min. Size: $4\frac{1}{2}W \times 4\frac{1}{2}D$
(114mm x 114mm)

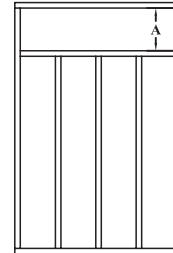

Style: DBOI 205
Min. Size: $5\frac{7}{8}W \times 3\frac{1}{8}D$
(149mm x 79mm)

*Horizontal Openings.
Dimensions A & B required.*

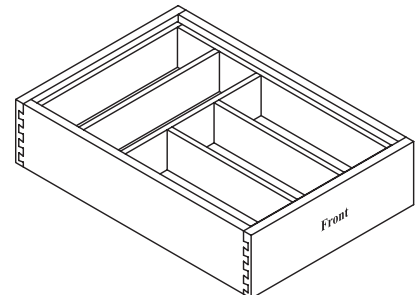
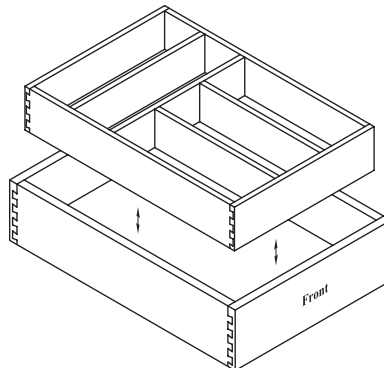
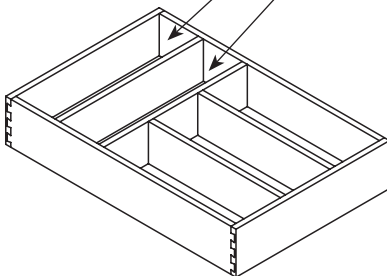

Note: Drawer Box and Drawer Box Organizer Insert are sold separately.

► **For PRICING** ► See Section **H.20** in our current Wholesale Pricing Catalog.



Series 300 - Drawer Box Organizer Inserts - DBOI (Solid Wood)

****Vertical dividers are equally spaced across the width of the organizer.**
****Height of horizontal openings (Dimensions A & B) are customer specified and must be provided.******

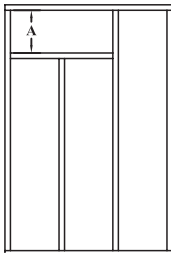
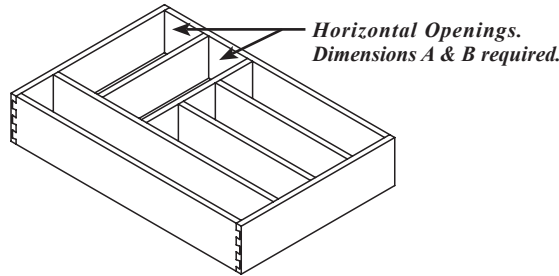

Style: DBOI 301L
 Min. Size: 4½Wx3⅜D
 (114mm x 79mm)

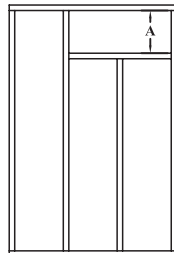

Style: DBOI 301R
 Min. Size: 4½Wx3⅜D
 (114mm x 79mm)

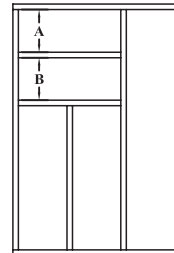

Style: DBOI 302L
 Min. Size: 4½Wx4½D
 (114mm x 114mm)

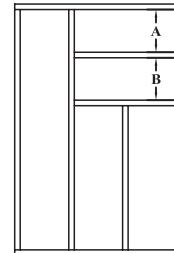

Style: DBOI 302R
 Min. Size: 4½Wx4½D
 (114mm x 114mm)

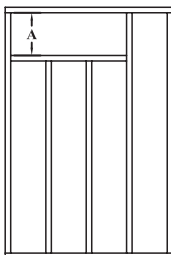

Style: DBOI 303L
 Min. Size: 5⅞Wx3⅜D
 (149mm x 79mm)

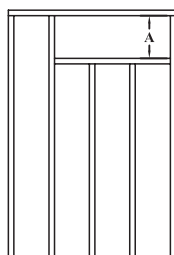

Style: DBOI 303R
 Min. Size: 5⅞Wx3⅜D
 (149mm x 79mm)

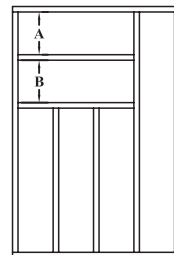

Style: DBOI 304L
 Min. Size: 5⅞Wx4½D
 (149mm x 114mm)

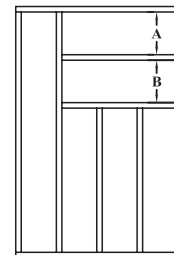

Style: DBOI 304R
 Min. Size: 5⅞Wx4½D
 (149mm x 114mm)

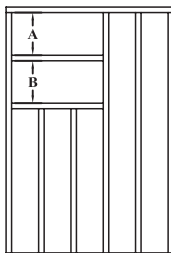

Style: DBOI 305L
 Min. Size: 7¼Wx4½D
 (184mm x 114mm)

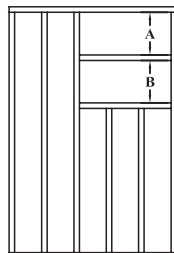

Style: DBOI 305R
 Min. Size: 7¼Wx4½D
 (184mm x 114mm)

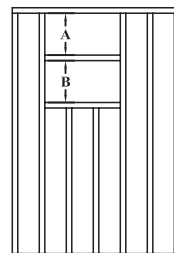

Style: DBOI 306L
 Min. Size: 8⅝Wx4½D
 (219mm x 114mm)

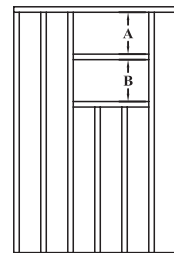

Style: DBOI 306R
 Min. Size: 8⅝Wx4½D
 (219mm x 114mm)

▶ **For PRICING** ▶ See Section **H.20** in our current Wholesale Pricing Catalog.

Series 400 - Drawer Box Organizer Inserts - DBOI (Solid Wood)

****All dividers are equally spaced.****

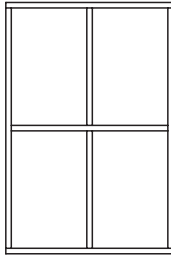
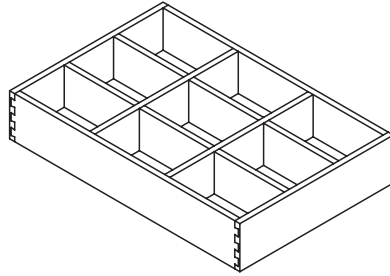

Style: DBOI 401
Min. Size: 3¼Wx3½D
(79mm x 79mm)

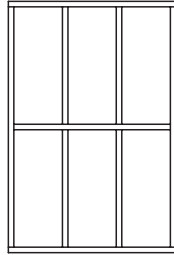

Style: DBOI 402
Min. Size: 4½Wx3½D
(114mm x 79mm)

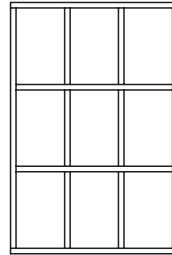

Style: DBOI 403
Min. Size: 4½Wx4½D
(114mm x 114mm)

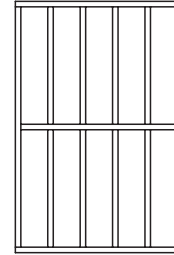

Style: DBOI 404
Min. Size: 7¼Wx3½D
(184mm x 79mm)

Ordering & Pricing Notes: Drawer Box Organizer Inserts

Ordering Guidelines

1	Order Drawer Box & DB Organizer Insert (DBOI) Together	Please use Drawer Box with Organizer Insert Order Form (E•Z Form #4i) . • This form is used to order both the drawer box and the drawer box organizer insert (DBOI).
		On each of the drawings in this section you will find the information that is required for ordering. • Spaces will be provided on the order form for the overall width and overall depth of the drawer box.
		When filling in the Drawer Box Style # along with the Drawer Box's exact Width, Depth and Height, you must also fill in the DB Organizer Insert (DBOI) #. Example: 304L . Be sure to include the height of horizontal openings (Dimensions A & B) where applicable.
		WalzCraft will determine the size of the DB Organizer Insert based on the size and specifications of the Drawer Box. We will figure finished dimensions, allowing for a 1.5mm gap around the perimeter of the Insert.
2	Order Drawer Box Organizer Insert Only	Please use Drawer Box Organizer Insert (DBOI) Only Order Form (E•Z Form #4.2) .
		On each of the drawings in this section you will find the information that is required for ordering. • Spaces will be provided on the order form for the overall width, depth and height of the insert.
		Order exact sizes only.
		Make sure to include the DB Organizer Insert (DBOI) #. Example: 304L . Make sure to include height of horizontal openings (Dimensions A & B) where applicable.
Pricing		
1	Pricing	Please see Section H.21 of our current Wholesale Pricing Catalog .
Notes continued on next page...		

► **For PRICING** ► See **Section H.20** in our current Wholesale Pricing Catalog.

Technical Notes: Drawer Box Organizer Inserts

Drawer Box Options - Solid Wood - Assembled (Chapter H)

1	Top Edge Option	Assembled: Available with TE6. See <i>Section H.1</i> .
2	Bottom Panel Inset	Assembled: Available with a 4.0mm bottom panel inset.
3	DBOI Construction	Only available with half blind dovetail joinery. See <i>Section H.1</i> .
4	Divider Installation	Dividers will be doweled into the sides / front / back.

Finish Options - Assembled (Chapter R)

1	Natural / Clear Coat (no stain)	<p>Assembled: Solid wood Drawer Box Organizer Inserts are available unfinished or finished with WalzCraft's <i>water base</i> "Natural/Clear Coat (no stain)" finish.</p> <ul style="list-style-type: none"> WalzCraft has used water base finish on drawer boxes since 2009. Water base finish is Urea Formaldehyde Free. No finish is applied to the underside of drawer box. <ul style="list-style-type: none"> Underside can be finished upon request, but additional charges will apply.
---	---------------------------------	--

Material Options

1	Sidewall Material	Available in solid wood only.
2	Maple - Hard vs. Soft	<p>All Series 400 DBOI's are not available in any Maple-Hard/Soft-Mixed species or Maple-Soft species. This is due to quality reasons for product requiring CNC machining.</p> <ul style="list-style-type: none"> This includes front, back, sides, and any dividers of all Series 400 DBOI's. These items should instead be ordered in any of our Maple-Hard species.
3	Bottom Panel	Bottom panel will be ¼" [6.4mm] plywood.

Ready to Assemble (RTA)

1	Ready to Assemble (RTA)	Drawer box organizer inserts are not available Ready to Assemble (RTA).
---	-------------------------	---

Sizes / Dimensions

1	Sidewall/Divider Thickness	Sidewalls and dividers are 9.5mm (⅜") thick.
2	Minimum Height	The minimum height of a DB Organizer Insert (DBOI) is 1¼" [44.5mm].
3	Maximum Size	<p>Drawer Box and DBOI Ordered Together: The maximum size for a DBOI ordered with a drawer box will be (Drawer Box Size - [DB side wall thickness x 2] - 3.0mm).</p> <ul style="list-style-type: none"> See <i>Sections H.1 through H.5</i> for maximum drawer box sizes. <p>DBOI Only: The maximum size for a DBOI will be the same as that of a drawer box.</p> <ul style="list-style-type: none"> See <i>Section H.1</i> for maximum drawer box size.
4	Divider Height	Dividers are 3.0mm shorter than the sidewalls (TE7 "look"). See <i>Section H.1</i> .
5	Placement	When ordered in conjunction with a drawer box (see <i>Ordering Guideline Note #1</i>), placement of the drawer box organizer will be ½" [12.7mm] below the shortest part of the drawer box sidewall.
6	Interior Opening Sizes	<p>The minimum dimension for the vertical or horizontal interior openings is 1" [25.4mm].</p> <ul style="list-style-type: none"> Example: Dimension A for DBOI 201 can not be less than 1" [25.4mm].

► For PRICING ► See *Section H.20* in our current Wholesale Pricing Catalog.

Drawer Boxes

Drawer Box Side Material

H

DBS100 *Solid Wood*

Standard D7 Edge Optional D29 Edge Optional D51 Edge

Shown with optional bottom panel dado groove.

DBS200 *Baltic Birch Plywood*

D7 Edge with Optional Edgeband (EBT201) Standard D7 Edge Optional D29 Edge Optional D51 Edge

Shown with optional bottom panel dado groove.

DBS300 *Standard Plywood*

Veneer Core MDF Core

D7 Edge with Optional Edgeband (EBT201) Standard D7 Edge D7 Edge with Optional Edgeband (EBT201) Standard D7 Edge

Shown with optional bottom panel dado groove.

DBS400 *Melamine*

D7 Edge with Optional Edgeband (EBT201) Standard D7 Edge

Shown with optional bottom panel dado groove.

Ordering & Pricing Notes: Drawer Box Side Material

Ordering Guidelines

1	Order Forms	Please use <i>Drawer Box Side Material / Divider Stock Order Form (E•Z Form #4.4)</i> .
2	Ordering Information	Use part #DBS100, #DBS200, #DBS300 or #DBS400 when ordering.
		No minimum order quantity required.

Pricing

1	Pricing	Please see <i>Section H.21</i> of our current Wholesale Pricing Catalog .
---	---------	--

Notes continued on next page...



Technical Notes: Drawer Box Side Material

Drawer Box Options (Chapter H)

1	Bottom Panel Dado Groove	Drawer Box Side Material is available with or without a bottom panel dado groove.
		Placement of Groove: Choose from any of the bottom panel placement options found in <i>Section H.6</i> of the Product Specifications Catalog .
		Width of Groove: Choose from any of the following widths: 0.225" [5.7mm], 0.250" [6.4mm], 0.450" [11.4mm] or 0.500" [12.7mm].
		Standard dado depth is fixed at 9/32" [7.0mm].

Finish Options (Chapter R)

1	Natural / Clear Coat (no stain)	Solid wood, baltic birch, veneer core plywood and MDF core plywood Drawer Box Side material is available unfinished or finished with Walzcraft's <i>solvent base</i> "Natural / Clear Coat (no stain)" finish.
		Drawer Box Side Material is finished on 2-sides (2S) and one long edge.

Material Options

1	DBS100 - Solid Wood	Choose from any of the wood species/grades from <i>Section N.12</i> of our current Wholesale Pricing Catalog .
2	DBS200 - Baltic Birch	See Birch-Baltic-Plywood-Mill Grade found in <i>Section K.1</i> of our current Wholesale Pricing Catalog
3	DBS300 - Plywood	Choose from any of the wood species/grades found in <i>Section K.1</i> of our current Wholesale Pricing Catalog .
4	DBS400 - Melamine	Choose from any of the colors found in <i>Section V.4</i> of our current Wholesale Pricing Catalog .
5	Edgebanding	If choosing a D7 with edgebanding (EBT201) , the edgeband material will always match the side material.

Profile Options (Chapter E)

1	DBS100 - Solid Wood	Outside Edge Profiles: Available with a D7, D29 or D51 profile.
2	DBS200 - Baltic Birch	Outside Edge Profiles: Available with a D7 (with or without edgeband), D29 or D51 profile.
3	DBS300 - Plywood DBS400 - Melamine	Outside Edge Profiles: Available with a D7 edge only (with or without edgebanding).

Sizes / Dimensions

1	DBS100 - Solid Wood	Thickness: 1/2" [12.7mm], 5/8" [15.9mm] and 3/4" [19.1mm] only.
		Width: Available in widths from 2" [50.8mm] up to 9" [228.6mm] in 1/16" increments or rounded to the nearest millimeter. All material over 6" [152.4mm] in width may be produced from a glued up panel due to lumber availability.
		Length: Available in lengths from 3" [76.2mm] up to 96" [2438.4mm]. If ordering random lengths (solid wood only), please order the total lineal footage needed.
2	DBS200 - Baltic Birch	Thickness: 12.5mm, 15.2mm and 18.0mm thicknesses.
		Width: Available in widths from 3" [76.2mm] up to 12" [304.8mm].
		Length: Available in lengths from 3" [76.2mm] up to 60" [1524.0mm].
3	DBS300 - Plywood	Thickness: 1/2" [12.7mm], 5/8" [15.9mm] and 3/4" [19.1mm] only.
		Width: Available in widths from 3" [76.2mm] up to 12" [304.8mm].
		Length: Available in lengths from 3" [76.2mm] up to 96" [2438.4mm].
4	DBS400 - Melamine	Thickness: 1/2", 5/8" and 3/4" nominal thicknesses only. See Melamine Sheet Stock in <i>Section V.4</i> for exact melamine thicknesses with tolerances.
		Width: Available in widths from 3" [76.2mm] up to 12" [304.8mm].
		Length: Available in lengths from 3" [76.2mm] up to 96" [2438.4mm].

Wood Specie Options (Chapter S)

1	Knotty & Rustic Grades	Knotty and Rustic grade materials will only have small knots, if any.
---	-----------------------------------	---

► For PRICING ► See Section H.21 in our current Wholesale Pricing Catalog.

Solid Wood Drawer Box Divider Stock - 3/16", 1/4", 3/8" and 1/2"



DBD100

Ordering & Pricing Notes: Drawer Box Divider Stock

Ordering Guidelines

1	Order Forms	Please use <i>Drawer Box Side Material / Divider Stock Order Form (E•Z Form #4.4)</i> .
2	Ordering Information	Use Part #DBD100 when ordering.
		No minimum order quantity required.
Pricing		
1	Pricing	Please see <i>Section H.22</i> of our current Wholesale Pricing Catalog .

Technical Notes: Drawer Box Divider Stock

Finish Options (Chapter R)

1	Natural / Clear Coat (no stain)	Solid wood Drawer Box Divider Stock is available unfinished or finished with Walzcraft's <i>solvent base</i> "Natural / Clear Coat (no stain)" finish.
		Drawer Box Divider Stock is finished on the face and back and all four edges.

Material Options

1	DBD100 - Solid Wood	Solid wood only. Choose from any of the wood species/grades from <i>Section N.12</i> of our current Wholesale Pricing Catalog .
----------	----------------------------	--

Molding Options (N)

1	Divider Moldings	The #845, #1686, #1687 & #1688 divider moldings can be used with divider stock, as shown on the following page.
----------	-------------------------	--

Profile Options (Chapter E)

1	Outside Edge Profile	Only available with a D7 outside edge profile.
----------	-----------------------------	---

Sizes / Dimensions

1	Thickness	Available in 3/16" [4.8mm], 1/4" [6.4mm], 3/8" [9.5mm] or 1/2" [12.7mm] thicknesses.
2	Width	Drawer Box Divider Stock is available in a minimum width of 5/8" [15.9mm] and a maximum width of 6" [152.4mm].
		6" [152.4mm] Maximum Width: WalzCraft makes every attempt to produce these parts from one solid piece of wood. Due to lumber availability and/or wood species, widths under 6" [152.4mm] may need to be made from two or more edge glued pieces. For widths over 6" [152.4mm], please refer to our GUPFS product found in <i>Section M.16</i> .
3	Length	Available in 8' [2438.4mm] lengths, Cut-to-Length or Random Lengths.
		The minimum length for Cut-to-Length pieces is 3" [76.2mm].
		Random Length sizes vary between 36" - 96" [914.4mm - 2438.4mm]. When measured, we round down to the next nearest 1/2 foot. Minimum quantity of 200 lineal feet.
		Solid wood drawer box divider stock has a standard length of up to 96" [2438.4mm]. Lengths greater than 8' [2438.4mm] are subject to availability. <i>Please note that the choice of wood species and grade can impact the availability of lengths greater than 8' [2438.4mm].</i>

Wood Specie Options (Chapter S)

1	Knotty & Rustic Grades	Knotty and Rustic grade materials will only have small knots, if any.
----------	-----------------------------------	---

Drawer Box Divider Molding

*Designed to accept
3/16" material*



#1686
PC: M102
Sq Ft: .72

*Designed to accept
3/8" material*



#1687
PC: M102
Sq Ft: .72

*Designed to accept
1/4" material*



#845
PC: M102
Sq Ft: .72

*Designed to accept
1/2" material*



#1688
PC: M102
Sq Ft: .72

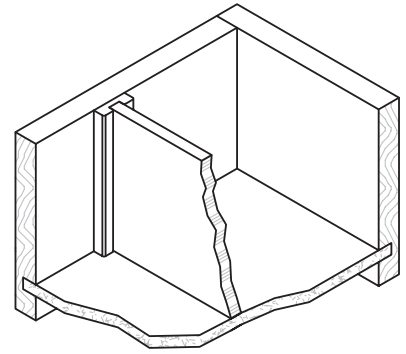

H

Ordering & Pricing Notes: Drawer Box Divider Molding

Ordering Guidelines

1	Order Forms	Please use <i>Molding & Miscellaneous Order Form (E-Z Form #5)</i> .
Pricing		
1	Pricing	Please see <i>Section N.9 & N.12</i> of our current Wholesale Pricing Catalog .

Technical Notes: Drawer Box Divider Molding

Miscellaneous

1	Application	Designed to be attached to the inside of drawer boxes.
----------	--------------------	--

Sizes / Dimensions

1	Available Lengths	Available in 8' [2438.4] lengths only.
2	Divider Moldings	Will accept divider material in 3/16" [4.8mm], 1/4" [6.4mm], 3/8" [9.5mm] or 1/2" [12.7mm] thicknesses.

► **For PRICING** ► See *Section N.9 & N.12* in our current Wholesale Pricing Catalog.

